

NO	DESCRIPTION	MATERIAL	Q'TY	FINISH	REMARK
1	BODY 1	SUS303	1	PASSIVATED	B-2401517-SUS
2	BODY 5	SUS303	1	PASSIVATED	B-2401520-SUS
3	GASKET	SI RUBBER	1	RUBBER	RU-0008
4	WASHER	SUS303	1	PASSIVATED	W-0012
5	INSULATION	UPE	1	UPE	I-0688P
6	PIN	BE CU	1	GOLD	P-2401029-G
7	BODY 5	BRASS	1	GOLD	B-2401512-G

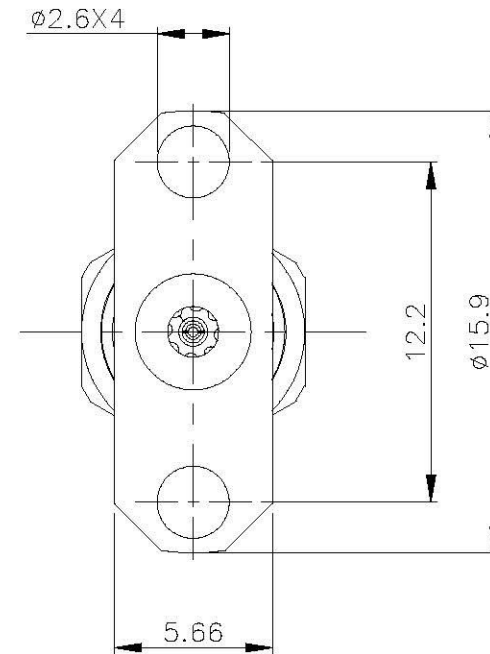
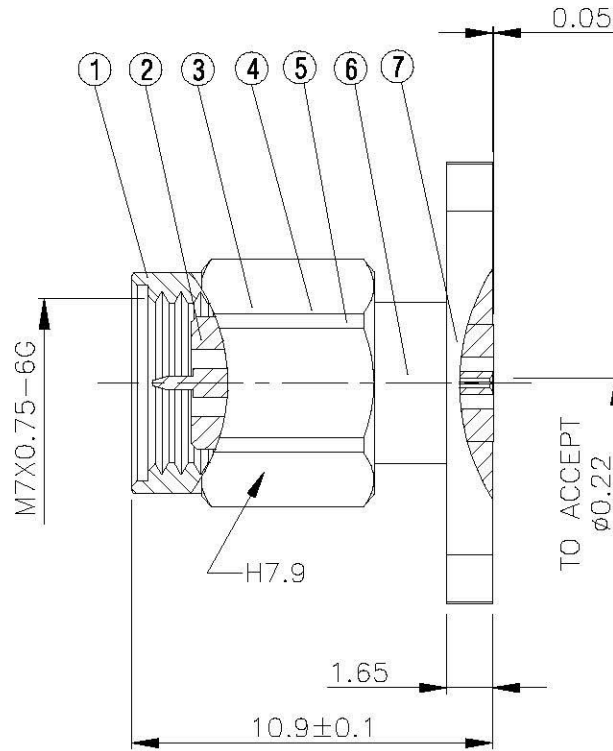
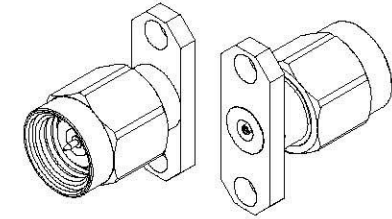

	All Connectors <small>www.allconnectors.de info@allconnectors.de</small> <small>Tel.: 0049 744 7008008 Fax: 0049 744 7008004</small> <small>70794 Ellersbach - Germany Kettnerstr. 25</small>	DRAWN DATE 98.11.13	DIMENSIONS ARE IN MILLIMETERS		REVISION	
		CHECKED DATE	UNLESS OTHERWISE SPECIFIED TOLERANCE		DESCRIPTION	ENGINEER
		Q.A. DATE	0.5-5=±0.2 120-315=±1			
		APPROVAL DATE	5-30=±0.4 315-1000=±1.6			
		REVISION DATE	30-120±0.6 1000-2000=±2.4	SCALE 4:1	SIZE A	
TITLE 240 MALE 2 HOLE MOUNT TO ACCEPT ø0.22	PART NO. 240-04-PGSUS					
DRAWING NO. 240-04-PGSUS						