

NO	DESCRIPTION	MATERIAL	Q'TY	FINISH	REMARK
1	BODY 1	BRASS	1	NICKEL	B-16560562-N
2	BODY 2	BRASS	2	GOLD	B-16560353-G
3	INSULATION	TEFLON	2	TEFLON	I-0173T
4	PIN	BRASS	1	GOLD	P-16560361-G
5	BODY 3	BRASS	2	NICKEL	B-16560354-N

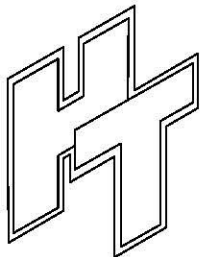
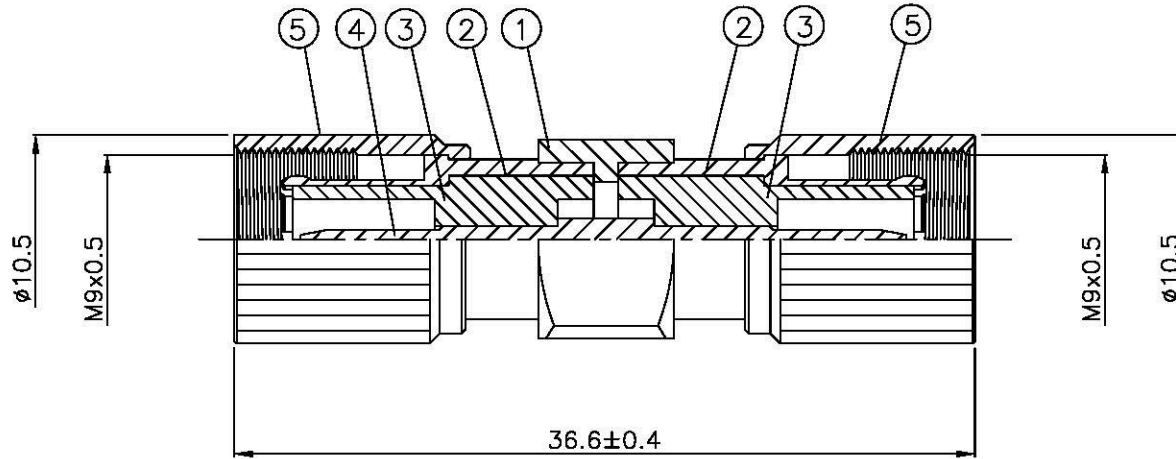
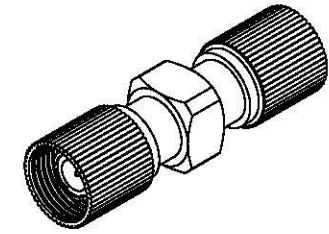

All Connectors

www.allconnectors.de
+49 694 711 20900
60256 Hildesheim - Germany

info@allconnectors.de
+49 694 711 20900
Kettelerstr. 25

TITLE
1.6/5.6 MALE -MALE ADAPTOR

PART NO. 1656-116-TGN

DRAWING NO. 1656 116 TGN

DRAWN MARY

DATE 90.03.03

CHECKED

蘇志欣

DATE

Q.A.

蘇姿潔

DATE

APPROVAL

徐燦霖

DATE

REVISION

DATE

DIMENSIONS ARE IN MILLIMETERS

UNLESS OTHERWISE SPECIFIED TOLERANCE

0.5-5=±0.2 120-315=±1
5-30=±0.4 315-1000=±1.6
30-120=±0.6 1000-2000=±2.4

SCALE 4:1 SIZE A

REVISION

DESCRIPTION ENGINEER