

NO	DESCRIPTION	MATERIAL	Q'TY	FINISH
1	SCREW	BRASS	1	NICKEL
2	BODY	BRASS	1	GOLD
3	BODY	BRASS	1	NICKEL
4	BODY	BRASS	1	NICKEL
5	INSULATION	TEFLON	1	TEFLON
6	INSULATION	TEFLON	1	TEFLON
7	PIN	BE CU	1	GOLD
8	WASHER	BRASS	1	SILVER
9	SPIGOT	BRASS	1	SILVER
10	BODY	BRASS	1	NICKEL

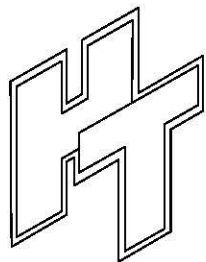
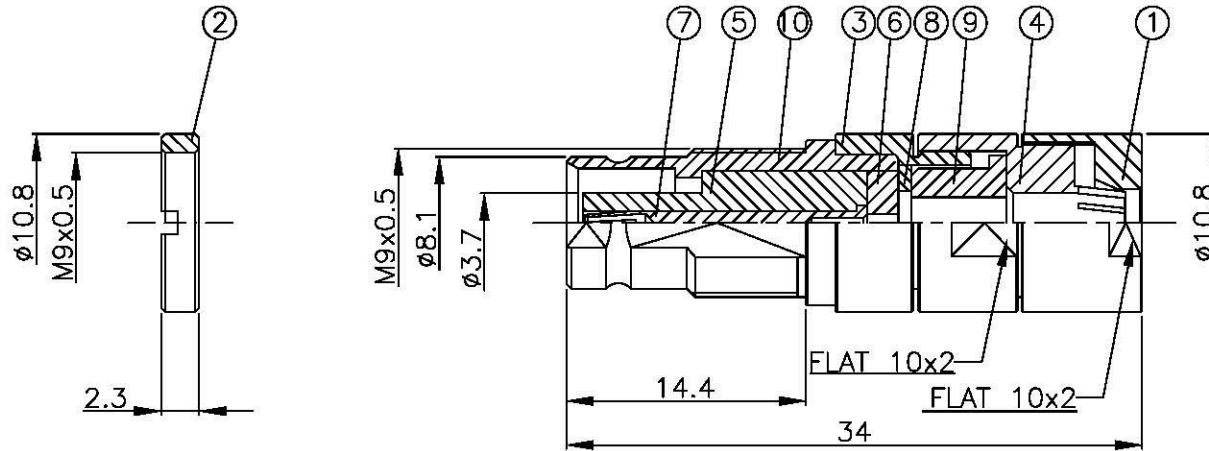
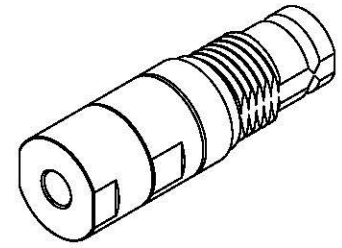
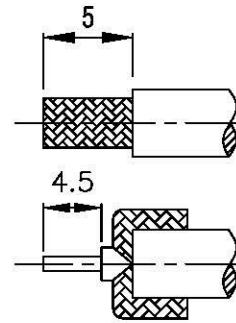

All Connectors

www.allconnectors.de
Tel.: 0049 431 7005000
70794 Filderstadt - Germany

info@allconnectors.de
Fax: 0049 431 7005001
Karl-Liebknecht-Str. 25

TITLE
**1.6/5.6 FEMALE CLAMP
FOR RG-179/U**

PART NO.
1656-112N-TGN

DRAWING NO. **1656 112N TGN**

DRAWN MARY

DATE 96.06.20

CHECKED 蘇志欣

DATE

Q.A. 蘇姿潔

DATE

APPROVAL 徐燦霖

DATE

REVISION

DATE

DIMENSIONS ARE IN MILLMETERS

UNLESS OTHERWISE SPECIFIED
TOLERANCES

0.5-5 = ±0.2	120-315 = ±1
5-30 = ±0.4	315-1000 = ±1.6
30-120 = ±0.6	1000-2000 = ±2.4

SCALE 4:1 SIZE A

REVISION

DESCRIPTION	ENGINEER