

NO	DESCRIPTION	MATERIAL	Q'TY	FINISH	REMARK
1	BODY 1	BRASS	1	NICKEL	B-16560351-N
2	BODY 2	BRASS	1	GOLD	B-16560350-G
3	INSULATION	TEFLON	1	TEFLON	I-0173T
4	PIN	PH.BRONZE	1	GOLD	P-16560224-G
5	NUT	BRASS	1	NICKEL	N-0025-N
6	WASHER	BRASS	1	NICKEL	W-0043-N
7	INSULATION	TEFLON	1	TEFLON	I-0175T
8	RING	BRASS	1	NICKEL	R-0039-N

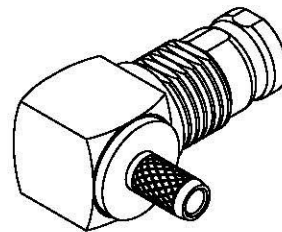

(Recommended Stripping Dimension)

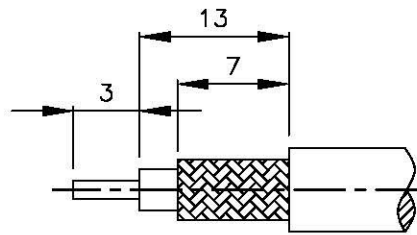
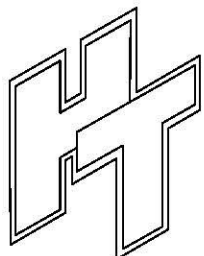
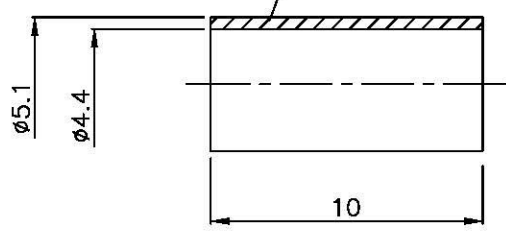
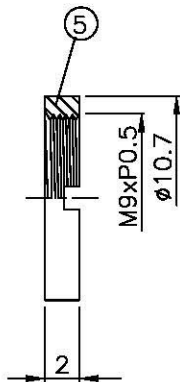
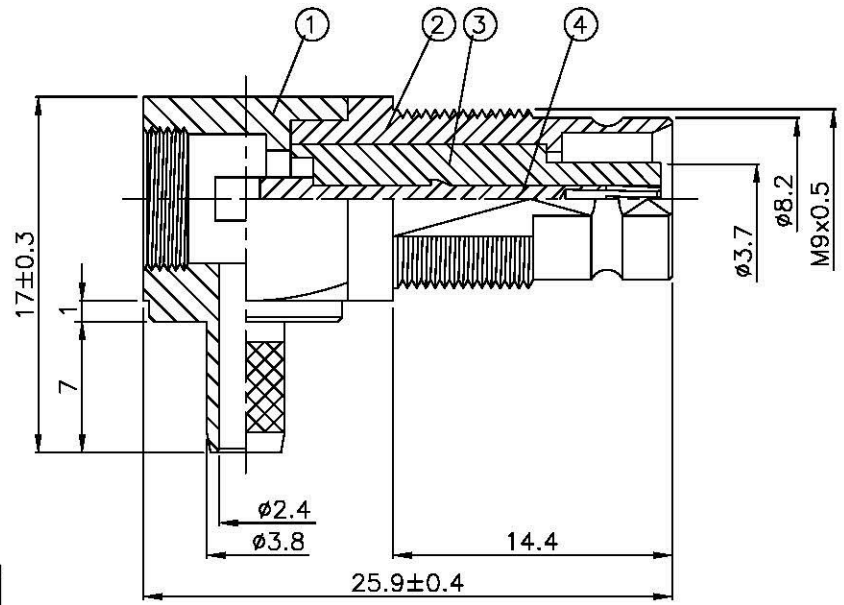
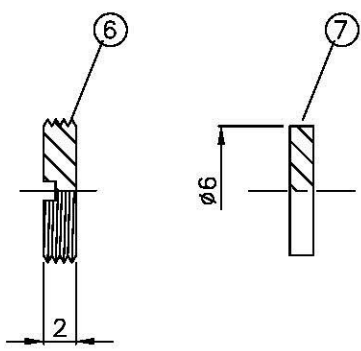

**All Connectors**  
 www.allconnectors.de  
 TEL: 0049 711 7009500  
 40754 Hildesheim, Germany  
 info@allconnectors.de  
 Fax: 0049 711 7009504  
 Kollmannstr. 25

**TITLE** 1.6/5.6 FEMALE CRIMP FOR FLEE 3 (ST 212)

**PART NO.** 1656-109V1C-TGN

**DRAWING NO.** 1656 109V1C TGN

**DRAWN** MARY **DATE** 96.08.27

**CHECKED** 蘇志欣 **DATE**

**Q.A.** 蘇姿潔 **DATE**

**APPROVAL** 徐燦霖 **DATE**

**REVISION** **DATE**

**DIMENSIONS ARE IN MILLIMETERS**

**UNLESS OTHERWISE SPECIFIED TOLERANCE**

0.5-5=±0.2    120-315=±1  
 5-30=±0.4    315-1000=±1.6  
 30-120=±0.6    1000-2000=±2.4

**SCALE** 4:1    **SIZE** A

REVISION	
DESCRIPTION	ENGINEER