

NO	DESCRIPTION	MATERIAL	Q'TY	FINISH	REMARK
1	BODY 1	BRASS	1	NICKEL	B-16560355-N
2	BODY 2	BRASS	1	GOLD	B-16560350-G
3	INSULATION	TEFLON	1	TEFLON	I-0173T
4	PIN	PH.BRONZE	1	GOLD	P-16560224-G
5	NUT	BRASS	1	NICKEL	N-0025-N
6	WASHER	BRASS	1	NICKEL	W-0043-N
7	INSULATION	TEFLON	1	TEFLON	I-0175T
8	RING	BRASS	1	NICKEL	R-0018-N

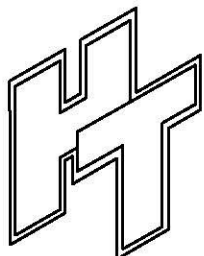
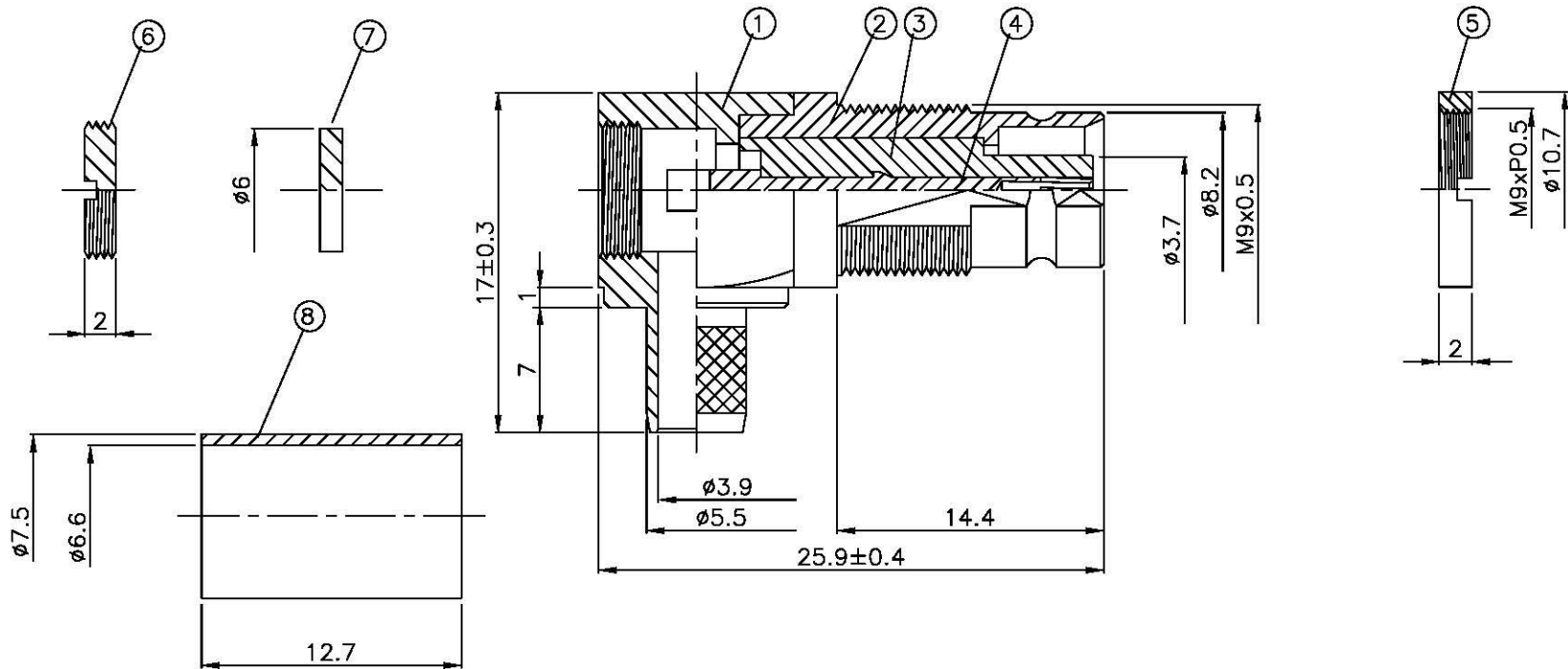
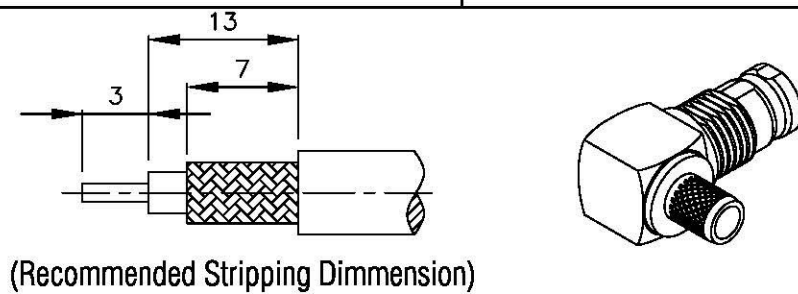

Allconnectors
 www.allconnectors.de
 info@allconnectors.de
 Tel: +49 211 2094503
 Fax: +49 211 2094504
 70781 Hilderstadt - Germany
 December 22

TITLE 1.6/5.6 FEMALE CRIMP FOR RG 59/U
PART NO. 1656-109G-TGN
DRAWING NO. 1656 109G TGN

DRAWN MARY
CHECKED 蘇志欣
Q.A. 蘇姿潔
APPROVAL 徐燦霖
REVISION

DATE 96.08.29
DATE
DATE
DATE

DIMENSIONS ARE IN MILLIMETERS
UNLESS OTHERWISE SPECIFIED TOLERANCE

0.5-5=±0.2 120-315=±1
 5-30=±0.4 315-1000=±1.6
 30-120=±0.6 1000-2000=±2.4

SCALE 4:1 **SIZE** A

REVISION	
DESCRIPTION	ENGINEER