

NO	DESCRIPTION	MATERIAL	Q'TY	FINISH
1	BODY 1	BRASS	1	NICKEL
2	BODY 2	BRASS	1	GOLD
3	INSULATION	TEFLON	1	TEFLON
4	PIN	BRASS	1	GOLD
5	BODY 3	BRASS	1	NICKEL
6	INSULATION	TEFLON	1	TEFLON
7	WASHER	BRASS	1	NICKEL
8	RING	BRASS	1	NICKEL

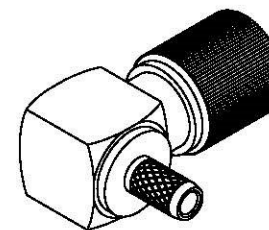

(Recommended Stripping Dimension)

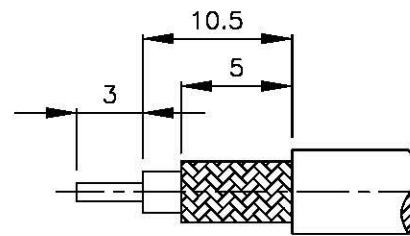
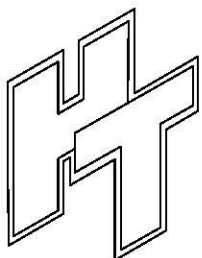
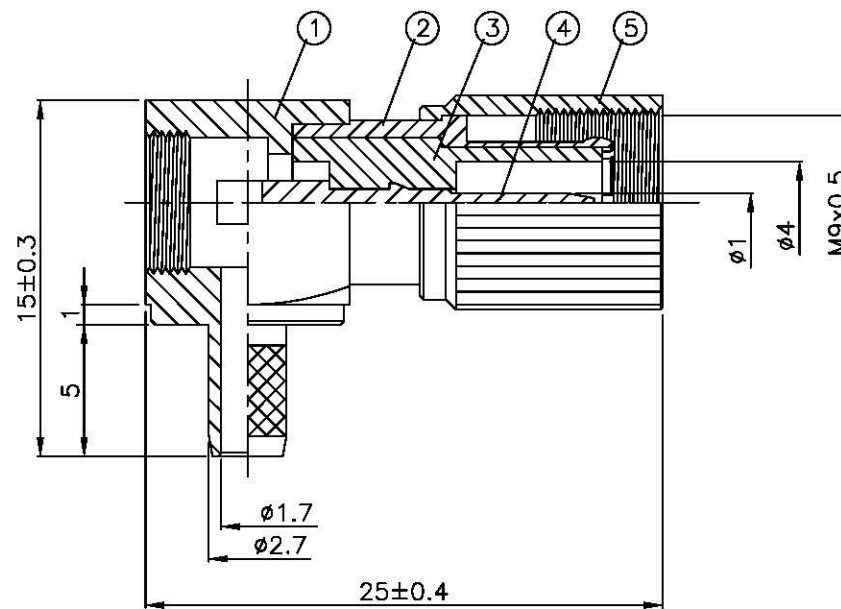
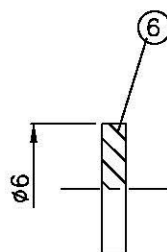
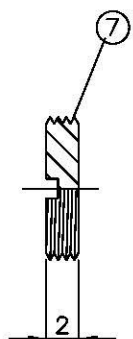
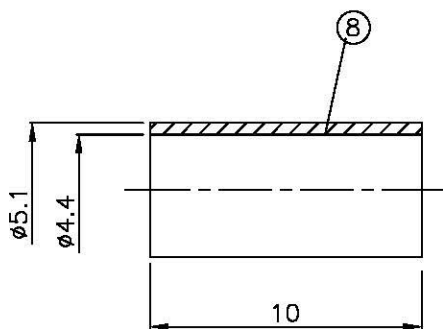

All Connectors

Address: 11011111111111111111
Tel: 00000 711 7000000
E-Mail: info@allconnectors.com

Address: 11011111111111111111
Fax: 00000 711 7000000
Website: www.allconnectors.com

TITLE 1.6/5.6 MALE CRIMP ANGLE FOR 179/U

PART NO. 1656-108N-TGN

DRAWING NO. 1656 108N TGN

DRAWN MARY

CHECKED 蘇志欣

Q.A. 蘇姿潔

APPROVAL 徐燦霖

REVISION

DATE 96.08.27

DATE

DATE

DATE

DATE

DIMENSIONS ARE IN MILLIMETERS

UNLESS OTHERWISE SPECIFIED TOLERANCE

0.5-5=±0.2 120-315=±1
5-30=±0.4 315-1000=±1.6
30-120=±0.6 1000-2000=±2.4

SCALE 4:1 SIZE A

REVISION

DESCRIPTION ENGINEER