

NO	DESCRIPTION	MATERIAL	Q'TY	FINISH	REMARK
1	BODY 1	BRASS	1	NICKEL	B-16560356-N
2	BODY 2	BRASS	1	GOLD	B-16560353-G
3	INSULATION	TEFLON	1	TEFLON	I-0176T
4	PIN	BRASS	1	GOLD	P-16560228-G
5	BODY 3	BRASS	1	NICKEL	B-16560354-N
6	RING	BRASS	1	NICKEL	R-0018-N

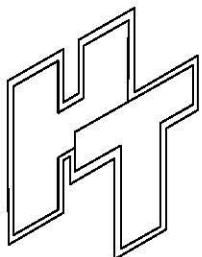
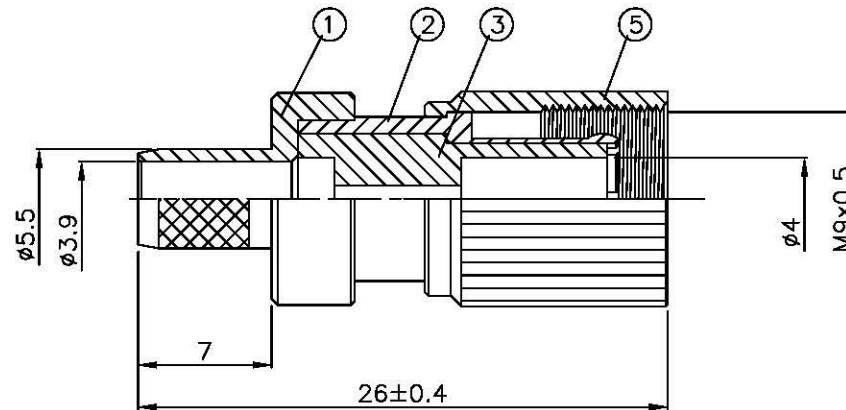
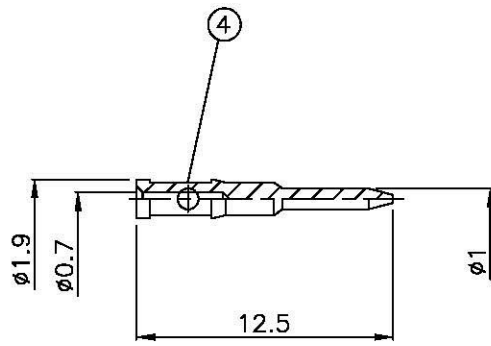
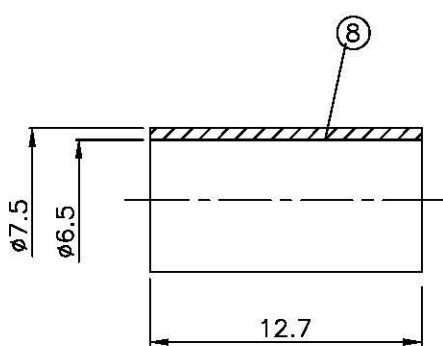
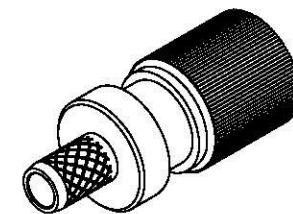
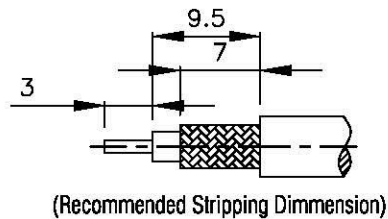

Allconnectors

www.allconnectors.com
Tel: 0049 711 7009503
D/7411 Metzingen - Germany

Info@allconnectors.com
Fax: 0049 711 7009504
Kontakt@allconnectors.com

TITLE **1.6/5.6 MALE CRIMP FOR 59/U**

PART NO. **1656-106G-TGN**

DRAWING NO. **1656 106G TGN**

DRAWN **MARY**

CHECKED **蘇志欣**

Q.A. **蘇姿潔**

APPROVAL **徐燦霖**

REVISION

DATE **96.08.27**

DATE

DATE

DATE

DATE

DIMENSIONS ARE IN MILLIMETERS

UNLESS OTHERWISE SPECIFIED TOLERANCE

0.5-5=±0.2 120-315=±1
5-30=±0.4 315-1000=±1.6
30-120=±0.6 1000-2000=±2.4

SCALE **4:1** SIZE **A**

REVISION

DESCRIPTION ENGINEER