

NO	DESCRIPTION	MATERIAL	Q'TY	FINISH	REMARK
1	BODY 1	BRASS	1	NICKEL	B-16560563-N
2	BODY 2	BRASS	1	GOLD	B-16560353-G
3	INSULATION	TEFLON	1	TEFLON	I-0176T
4	PIN	BRASS	1	GOLD	P-16560362-G
5	BODY 3	BRASS	1	NICKEL	B-16560354-N
6	INSULATION	TEFLON	1	TEFLON	I-0251T

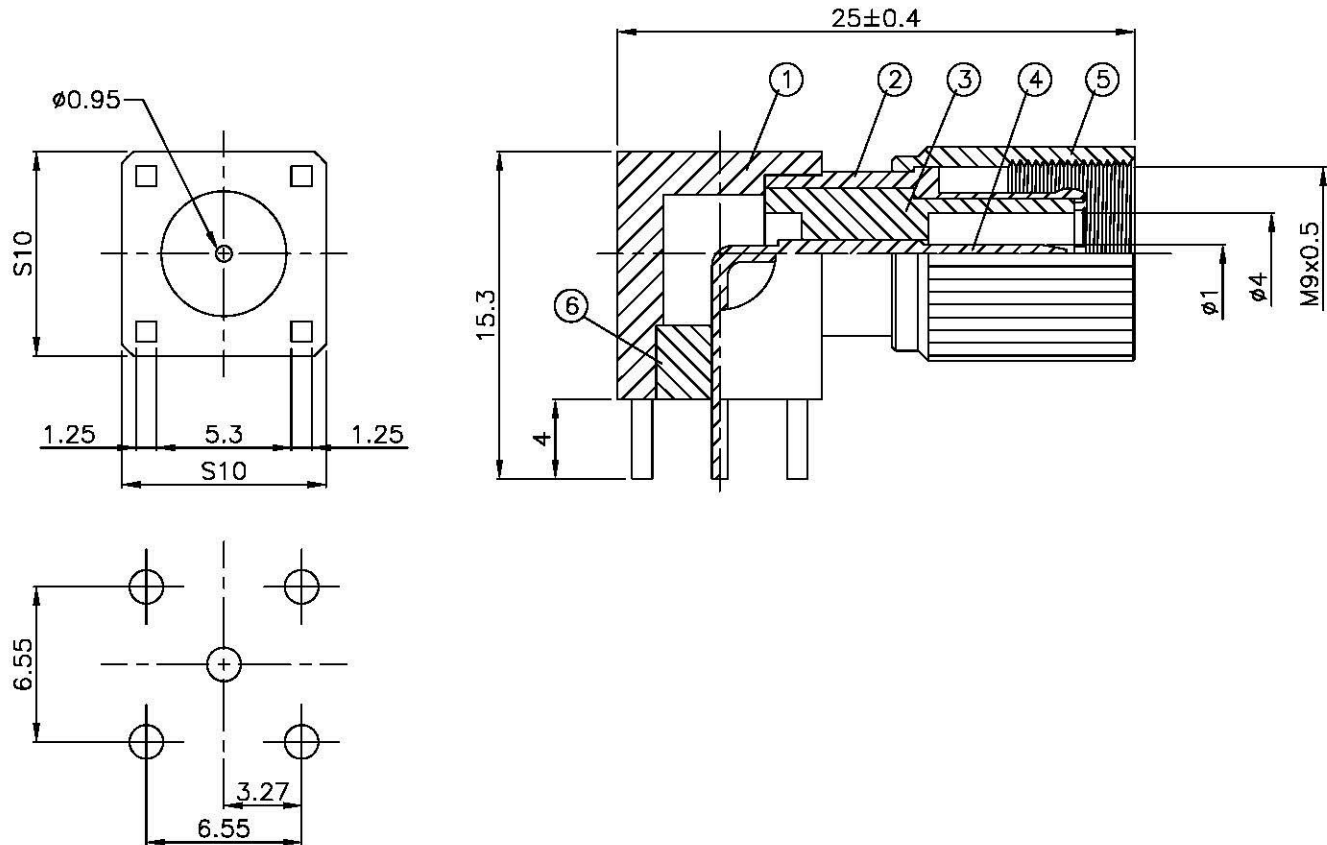

PC MOUNTING

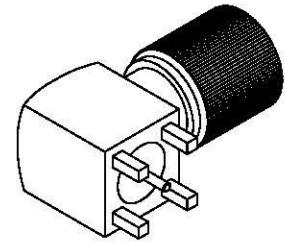
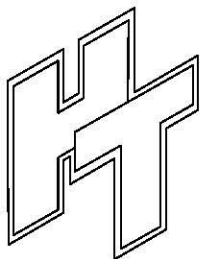

Allconnectors

www.allconnectors.de
T. +49 049 211 7009165
AG 751 Hilberstadt Germany

Info@allconnectors.de
F. +49 049 211 7009164
K. +49 049 211 7009165

TITLE **1.6/5.6 MALE ANGLE
PCB MOUNTING**

PART NO. **1656-105-TGN**

DRAWING NO. **1656 105 TGN**

DRAWN **MARY**

DATE **96.08.29**

CHECKED

蘇志欣

DATE

Q.A.

蘇姿潔

DATE

APPROVAL

徐燦霖

DATE

REVISION

DATE

DIMENSIONS ARE IN MILLIMETERS

UNLESS OTHERWISE SPECIFIED
TOLERANCE

0.5-5=±0.2	120-315=±1
5-30=±0.4	315-1000=±1.6
30-120=±0.6	1000-2000=±2.4

SCALE **4:1** SIZE **A**

REVISION

DESCRIPTION

ENGINEER