

NO	DESCRIPTION	MATERIAL	Q'TY	FINISH
1	BODY 1	BRASS	1	NICKEL
2	BODY 2	BRASS	1	GOLD
3	INSULATION	TEFLON	1	TEFLON
4	PIN	PH.BRONZE	1	GOLD
5	NUT	BRASS	1	NICKEL
6	WASHER	BRASS	1	NICKEL
7	INSULATION	TEFLON	1	TEFLON
8	WASHER	BRASS	1	SILVER
9	SPIGOT	BRASS	1	SILVER
10	BODY	BRASS	1	NICKEL
11	SHELL	BRASS	1	TEFLON

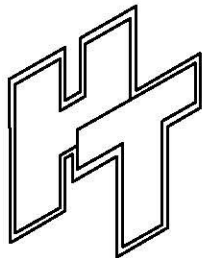
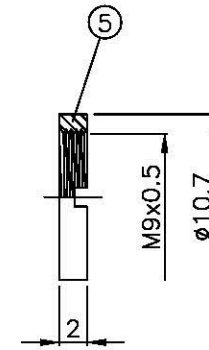
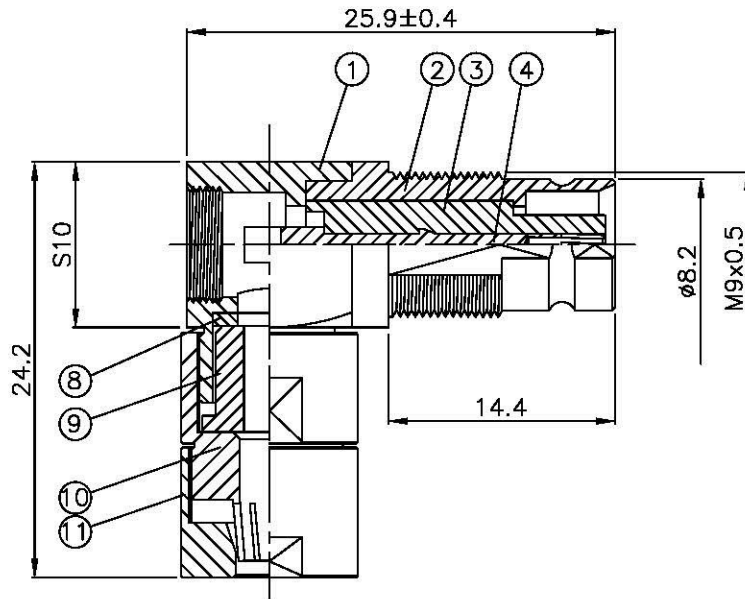
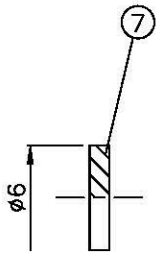
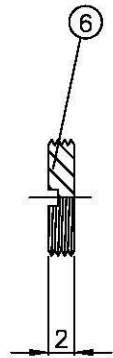
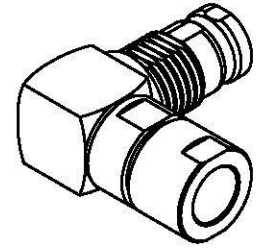

All Connectors

www.allconnectors.com
 Tel: 0049 211 260001
 70751 Pfladerbach - Germany

info@allconnectors.com
 Fax: 0049 211 260005
 Kettnerstr. 25

TITLE 1.6/5.6 FEMALE ANGLE CRIMP
 FOR RG-59/U

PART NO. 1656-102G-TGN

DRAWING NO. 1656 102G TGN

DRAWN MARY

DATE 96.08.26

CHECKED 蘇志欣

DATE

Q.A. 蘇姿潔

DATE

APPROVAL 徐燦霖

DATE

REVISION

DATE

DIMENSIONS ARE IN MILLIMETERS

UNLESS OTHERWISE SPECIFIED
 TOLERANCE

0.5-5 = ±0.2 120-315 = ±1
 5-30 = ±0.4 315-1000 = ±1.6
 30-120 = ±0.6 1000-2000 = ±2.4

SCALE 4:1 SIZE A

REVISION

DESCRIPTION ENGINEER
