

| NO | DESCRIPTION | MATERIAL | Q'TY | FINISH | REMARK       |
|----|-------------|----------|------|--------|--------------|
| 1  | BODY 1      | BRASS    | 1    | NICKEL | B-16560545-N |
| 2  | BODY 2      | BRASS    | 1    | GOLD   | B-16560353-G |
| 3  | INSULATION  | TEFLON   | 1    | TEFLON | I-0173T      |
| 4  | PIN         | BRASS    | 1    | GOLD   | P-16560224-G |
| 5  | BODY 3      | BRASS    | 1    | NICKEL | B-16560354-N |
| 6  | WASHER      | BRASS    | 1    | NICKEL | W-0043-N     |
| 7  | INSULATION  | TEFLON   | 1    | TEFLON | I-0175T      |
| 8  | WASHER      | BRASS    | 1    | SILVER | W-0050-S     |
| 9  | SPIGOT      | BRASS    | 1    | SILVER | B-16560544-S |
| 10 | BODY 4      | BRASS    | 1    | NICKEL | B-16560543-N |
| 11 | SHELL       | BRASS    | 1    | TEFLON | N-0028-N     |

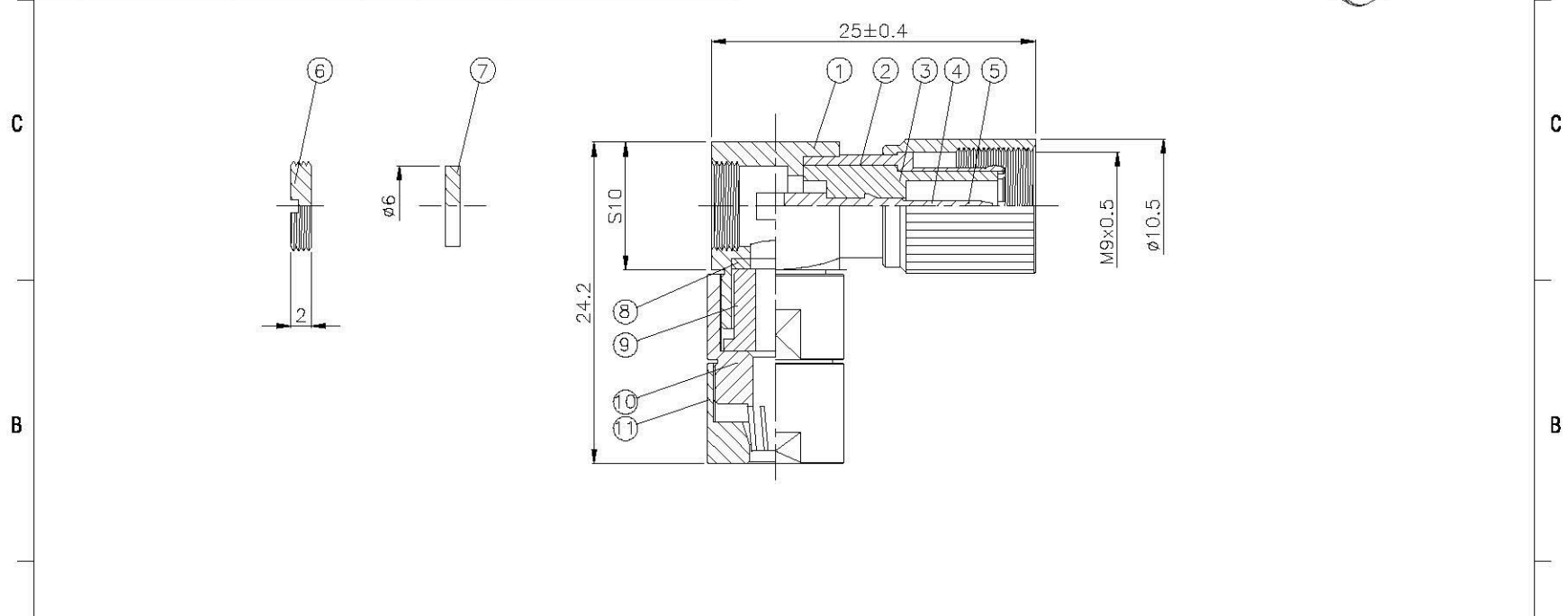
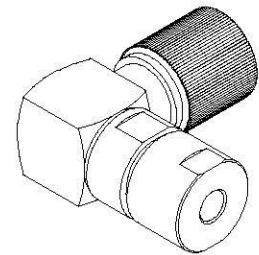

|  |   |  |   |                                       |  |             |          |   |
|--|---|--|---|---------------------------------------|--|-------------|----------|---|
|  | <b>Allconnectors</b><br><small>www.allconnectors.de<br/>Tel: 0619 711 700550<br/>78744-Wehrstedt, Germany</small> |  | DRAWN MARY<br>CHECKED 蘇志欣<br>Q.A. 蘇姿潔<br>APPROVAL 徐燦霖<br>REVISION | DATE 93.07.16<br>DATE<br>DATE<br>DATE | DIMENSIONS ARE IN MILLIMETERS<br>UNLESS OTHERWISE SPECIFIED TOLERANCE<br>0.5-5=±0.2    120-315=±1<br>5-30=±0.4    315-1000=±1.6<br>30-120=±0.6    1000-2000=±2.4 | REVISION    |          | A |
|  | TITLE 1.6/5.6 MALE ANGLE CLAMP FOR FLEX 3   |  |   |                                       |  | DESCRIPTION | ENGINEER |   |
|  | PART NO. 1656-101V1C-TGN  |  |   |                                       |  |             |          |   |
|  | DRAWING NO. 1656 101V1C TGN   |  |   |                                       |  |             |          |   |
|  |   |  |   |                                       |  | SCALE 4:1   | SIZE A   |   |