

NO	DESCRIPTION	MATERIAL	Q'TY	FINISH
1	BODY 1	BRASS	1	NICKEL
2	BODY 2	BRASS	1	GOLD
3	INSULATION	TEFLON	1	TEFLON
4	PIN	BRASS	1	GOLD
5	BODY 3	BRASS	1	NICKEL
6	WASHER	BRASS	1	NICKEL
7	INSULATION	TEFLON	1	TEFLON
8	WASHER	BRASS	1	SILVER
9	SPIGOT	BRASS	1	SILVER
10	BODY 4	BRASS	1	NICKEL
11	SHELL	BRASS	1	TEFLON

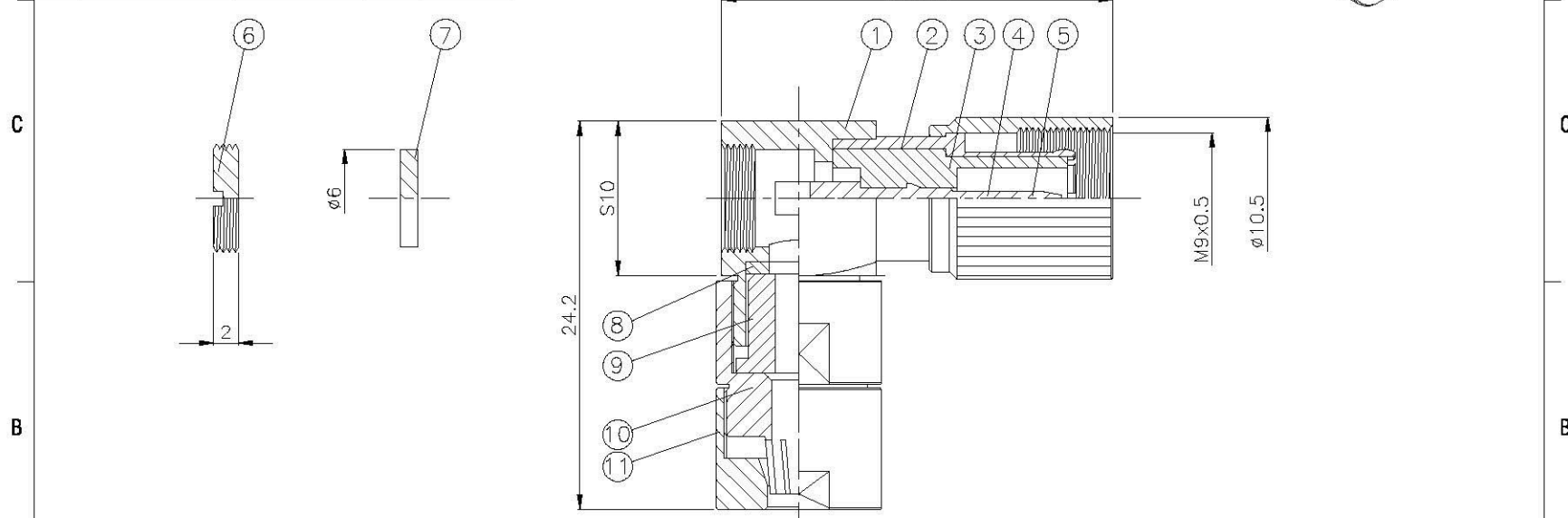
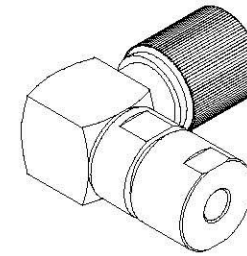

	Allconnectors <small>www.allconnectors.de info@allconnectors.de Tel: 0049 7031 900000 Fax: 0049 7031 900004 70364 Filsdorferstr. Germany Kempten, Germany</small>	DRAWN MARY	DATE 93.08.26	DIMENSIONS ARE IN MILLIMETERS		REVISION	
	TITLE 1.6/5.6 MALE ANGLE CLAMP FOR RG-179/U	CHECKED 	DATE	UNLESS OTHERWISE SPECIFIED TOLERANCE		DESCRIPTION	ENGINEER
	PART NO. 1656-101N-TGN	Q.A. 	DATE			0.5-5=±0.2	120-315=±1
	DRAWING NO. 1656 101N TGN	APPROVAL 	DATE	5-30=±0.4	315-1000=±1.6		
		REVISION	DATE	30-120=±0.6	1000-2000=±2.4		
			SCALE 4:1	SIZE A			