

NO	DESCRIPTION	MATERIAL	Q'TY	FINISH	REMARK
1	BODY 1	BRASS	1	GOLD	B-10230713-G
2	INSULATION	TEFLON	1	TEFLON	I-0345T
3	PIN	BRASS	1	GOLD	P-10230497-G
4	BODY 3	BRASS	1	GOLD	B-10230711-G
5	WASHER	BE CU	1	NICKEL	W-0051-N
6	WASHER	BRASS	1	GOLD	W-0057-G
7	RING	BRASS	1	GOLD	R-0001-G

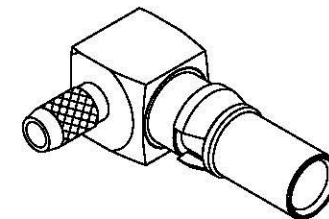

(Recommended Stripping Dimension)

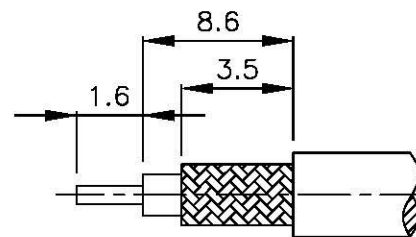
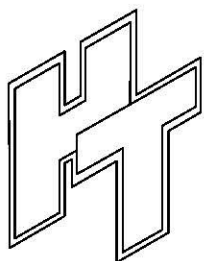
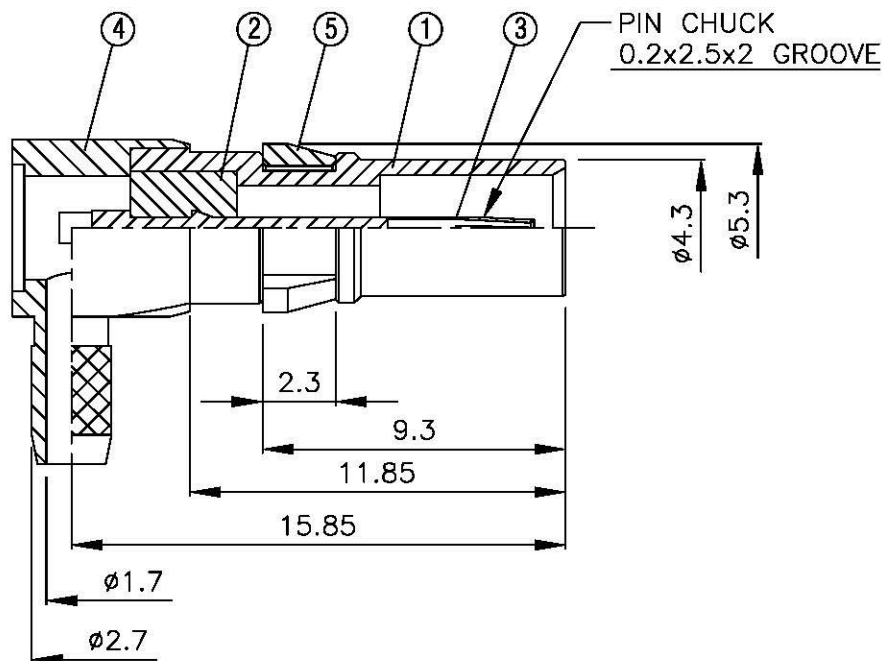
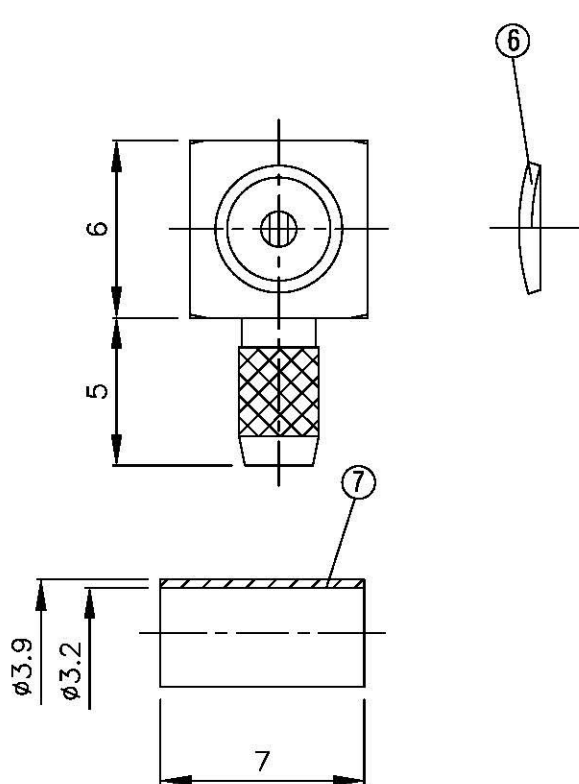

All Connectors

www.allconnectors.de
 info@allconnectors.de
 70791 Gilderstadt - Germany

TITLE 1.0/2.3 FEMALE CRIMP ANGLE FOR
 RG-179/U (75 OHM)

PART NO. 1023-17N-TGG

DRAWING NO. 1023 17N TGG

DRAWN MARY DATE 96.07.16

CHECKED 蘇志欣 DATE

Q.A. 蘇姿潔 DATE

APPROVAL 徐燦霖 DATE

REVISION DATE

DIMENSIONS ARE IN MILLIMETERS

UNLESS OTHERWISE SPECIFIED
 TOLERANCE

0.5-5=±0.2 120-315=±1

5-30=±0.4 315-1000=±1.6

30-120±0.6 1000-2000=±2.4

SCALE 4:1 SIZE A

REVISION

DESCRIPTION ENGINEER

D

C

B

A

D

C

B

A

4

3

2

1