

NO	DESCRIPTION	MATERIAL	Q'TY	FINISH	REMARK
1	BODY 1	BRASS	1	GOLD	B-10230710-G
2	BODY 2	BE CU	1	GOLD	B-10230708-G
3	INSULATION	TEFLON	1	TEFLON	I-0343T
4	PIN	BRASS	1	GOLD	P-10230491-G
5	BODY 3	BRASS	1	GOLD	B-10230592-G
6	INSULATION	TEFLON	1	TEFLON	I-0344T
7	WASHER	BE CU	1	NICKEL	W-0051-N

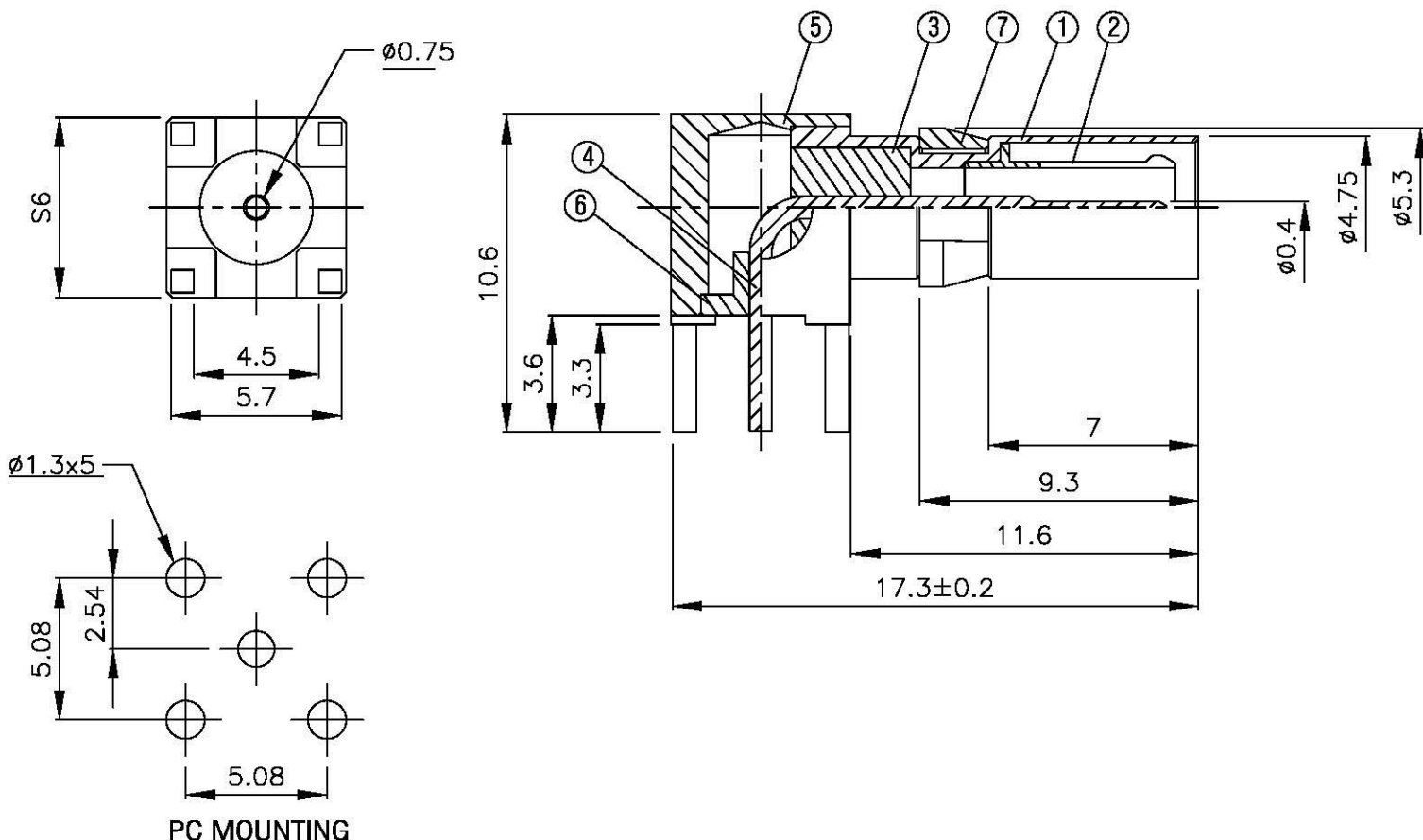
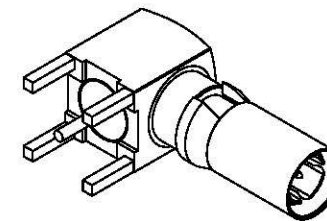

		DRAWN MARY DATE 96.07.16	DIMENSIONS ARE IN MILLIMETERS		REVISION	
	<small>www.allconnectors.com tel: 00852 2711 4099 address: allconnectors.com</small>	CHECKED 蘇志欣 DATE	UNLESS OTHERWISE SPECIFIED TOLERANCE		DESCRIPTION	ENGINEER
	TITLE 1.0/2.3 MALE ANGLE PCB MOUNT -75 ohm	Q.A. 蘇姿潔 DATE	0.5-5 = ± 0.2	120-315 = ± 1		
	PART NO. 1023-12-TGG-75	APPROVAL 徐燦霖 DATE	5-30 = ± 0.4	315-1000 = ± 1.6		
	DRAWING NO. 1023 12 TGG-75	REVISION DATE	30-120 = ± 0.6	1000-2000 = ± 2.4		
		SCALE 4:1	SIZE A			