

NO	DESCRIPTION	MATERIAL	Q'TY	FINISH	REMARK
1	BODY 1	BRASS	1	GOLD	B-SMB0172-G
2	INSULATION	TEFLON	1	TEFLON	I-0343T
3	BODY 2	BRASS	1	GOLD	B-10230709-G
4	WASHER	BE CU	1	NICKEL	W-0051-N
5	BODY 3	BE CU	1	GOLD	B-10230708-G
6	PIN	PH.BRONZE	1	GOLD	P-10230490-G
7	RING	BRASS	1	GOLD	R-0001-G

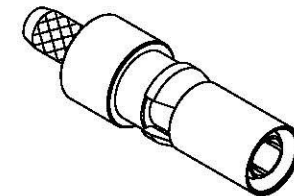
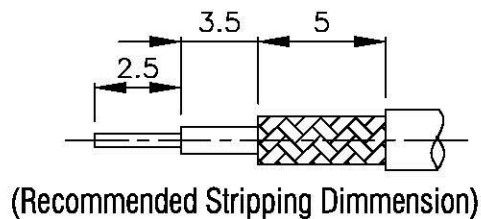

D

D

C

C

B

B

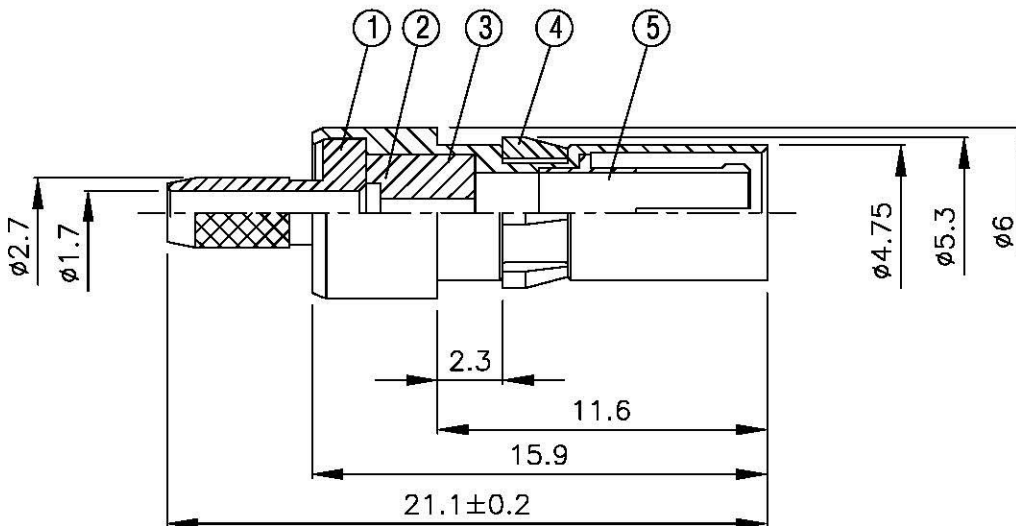
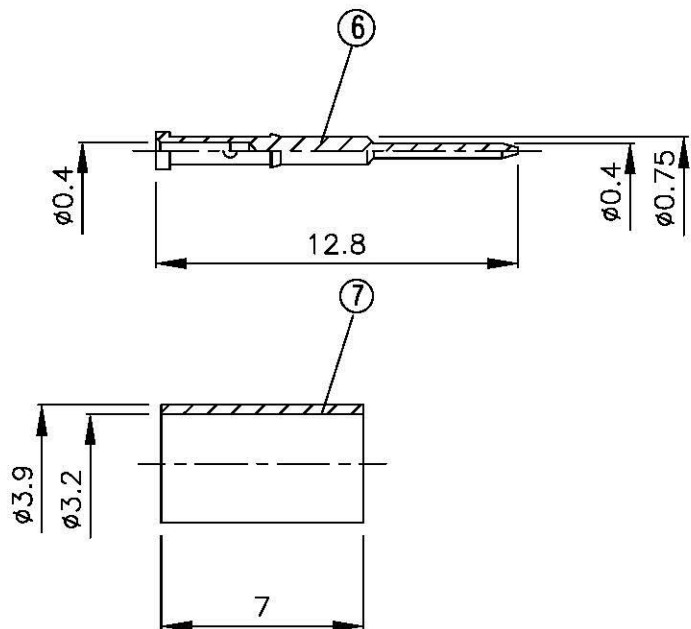

A

A

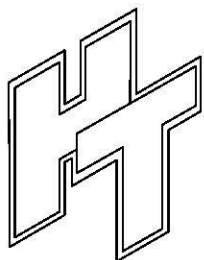

**All Connectors**

www.allconnectors.de  
Info: 0049 711 7009004  
Koblenz, Germany

info@allconnectors.de  
Fax: 0049 711 7009004  
Koblenz, Germany

TITLE 1.0/2.3 MALE CRIMP FOR  
RG-179/U ( 75 OHM)

PART NO. 1023-07N-TGG

DRAWING NO. 1023 07N TGG

DRAWN MARY DATE 96.07.16

CHECKED 蘇志欣 DATE

Q.A. 蘇姿潔 DATE

APPROVAL 徐燦霖 DATE

REVISION DATE

DIMENSIONS ARE IN MILLIMETERS

UNLESS OTHERWISE SPECIFIED  
TOLERANCE

0.5-5=±0.2 120-315=±1

5-30=±0.4 315-1000=±1.6

30-120±0.6 1000-2000=±2.4

SCALE 4:1 SIZE A

REVISION

DESCRIPTION ENGINEER

4

3

2

1