

A | B | C | D | E | F | G | H

6

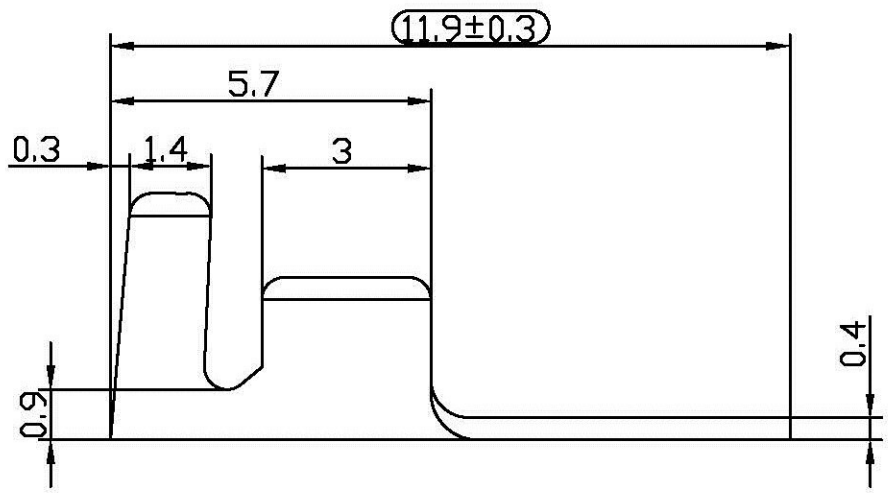

其余 $\sqrt{3.2}$

6

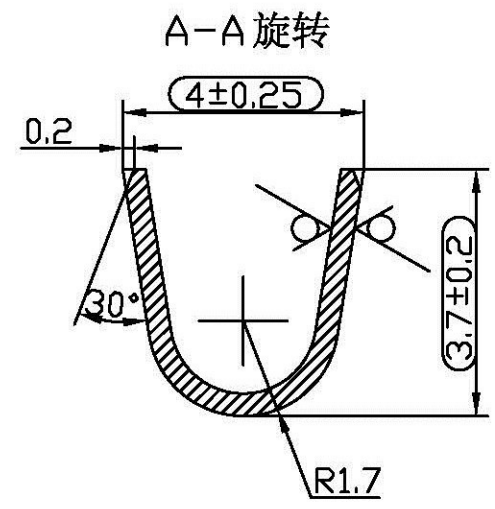

5

4

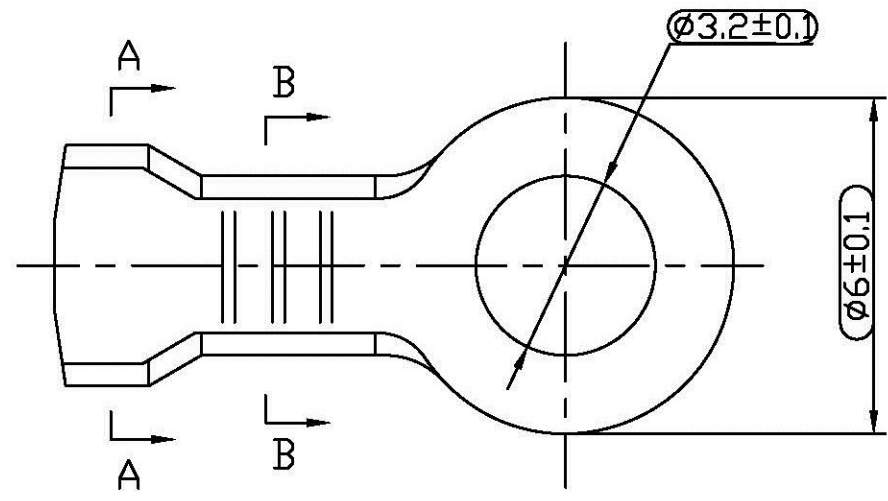

4

B-B 旋转

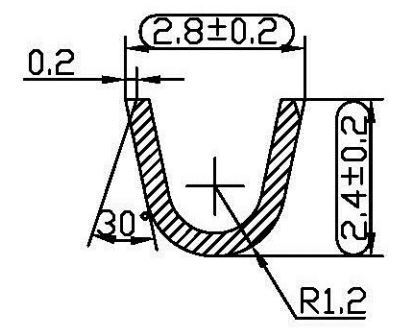

3

3

2

Symbol Description		Control size
--------------------	--	--------------

2

Technical Remarks:

- 1, The part must be free of hazard burrs, pointed, sharp edges and mechanical damage.
- 2, The Plating should be uniform, bright, no defects such as fog spot and delamination.
- 3, Tolerance is not injected by GB1804-M-class.

Plating		Cu/Ep. Cu10Sn3-5m	
UNLESS OTHERWISE SPECIFIED ALL DIMENSIONS ARE IN MM			
TOLERANCES:			
MARK	REV	NAME	DATE
DESIGNER	XUWUYU	2007.11.07	SIZE
CHECKED	MEIJIAOLONG	2007.11.07	REV
APPROVAL	JIYAOHU	2007.11.07	SCALE
WHOLE NO. ±0.2		DECIMAL ±0.1	ANGLE ±0.5°
PAGE		1/1	
MATERIAL :BRASS (H62 Y δ=0.4)			
MODEL: OH-326004			
FILE NO.: ZR7.731.248			

1

A | B | C | D | E | F | G | H