

# 產品成品圖

Terminal

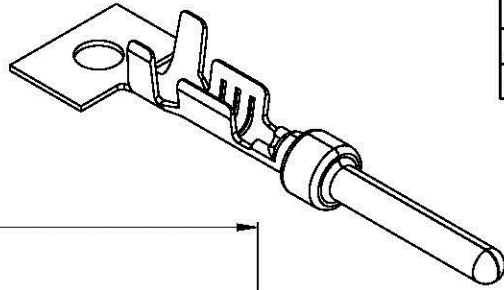

品號	IS	WS	H8	H9
A00124BS-2	3.2	2.2	2.4	3.4
A00124BS-2S	2.8	2.0	2.0	2.7

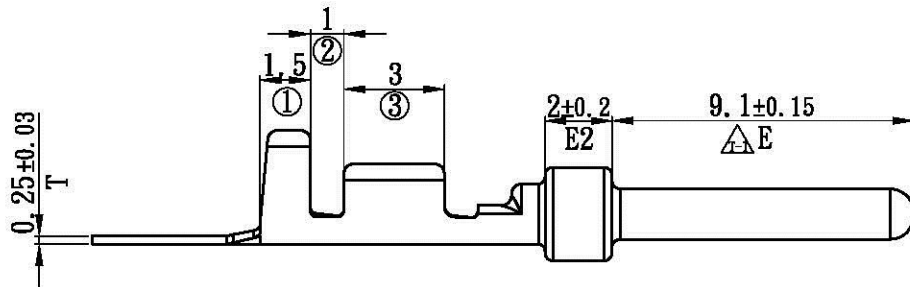
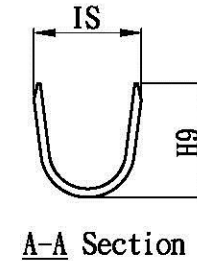
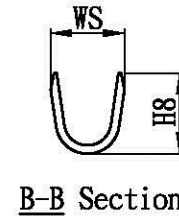
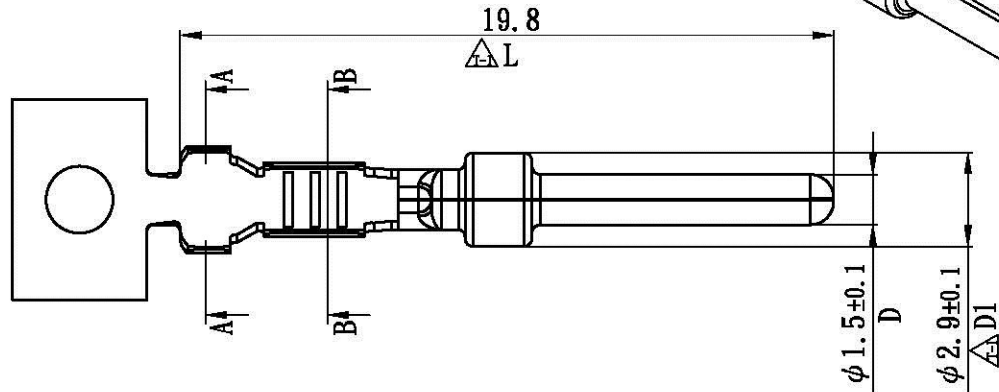

預鍍錫編號[Part No.(Tin-plated before press/forming)]  
A00124BS-2  
A00124BS-2S

表面處理(Surface treatment):  
預鍍錫膜厚40 μ" 以上  
(Pre-tin-plated thickness more than 40 μ")

適用電線(Applicable wire):  
-2:AWG# 18-20(1007)  
-2S:AWG# 22-24(1007)

線皮外徑(Insulation O.D):  
-2:2.1~1.9 mm  
-2S:1.7~1.5mm

包裝數量(Standard packing):  
6000 PCS

此產品須符合RoHS指令要求  
(The product must conform to the RoHS directive)

**All Connectors**

www.allconnectors.de  
Tel.: 0049 711 7099003  
A0/94 Hildersried, Germany

info@allconnectors.de  
Fax: 0049 711 7099004  
Hildersried, D

UL NO:	CSA NO:	TUV NO:	名稱(Name): 產品規格(Product specifications)			核發單位 (Issued by)	制定單位 (Instituted by)
			編號(Part No.): A00124BS			部品部 2009.06.01 核發	開發課 2009.05.20 制定
			材質(Material): 黃銅[Brass]				
△	端子前端改無圓孔，修正L、E、D1尺寸規格	T-2	20-May-09	核准 (Approved by)	審查 (Confirmed by)	制定 (Drawn by)	單位(Unit):mm 比例(Scale):Free
		T-1	02-May-08				
記號 (Sign)	變更內容 (Change description)	版次 (Edition)	制修訂日期 (Drawn date)	韓曜安	韓曜安	許世杰	第三角法 (Projection): 一般公差 (General tolerance): ±0.3