

NOTE:
 1.MATERIAL: HOUSING:PBT UL 94-V0
 TERMINAL:PHOSPHOR BRONZE
 2.FLASH:0.1mm MAX. CAMBER0.05mm MAX.
 DEFORMATION:NA. WARP:0.05mm MAX.

WT-DZ-xx-NF
 | NON/LEADFREE
 02:2PIN
 |
 25:25PIN

RoHS Compliant

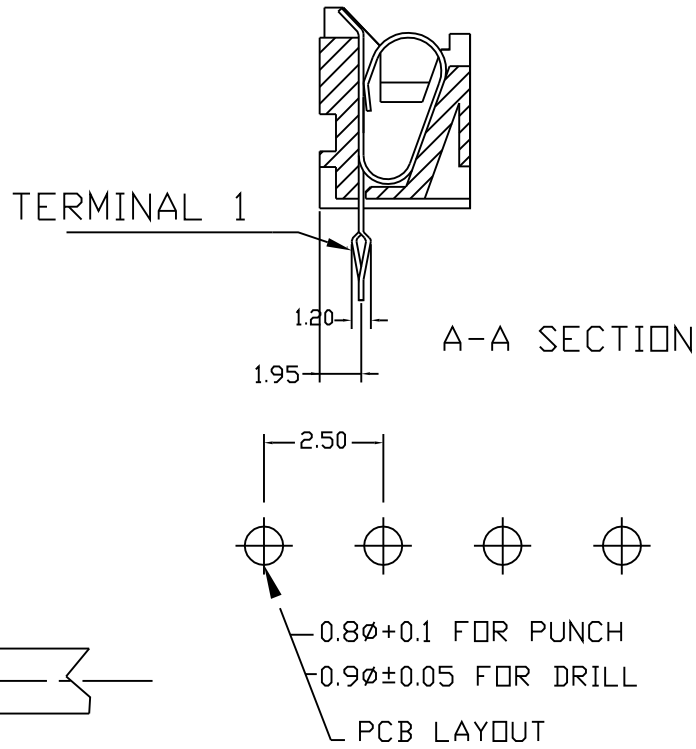
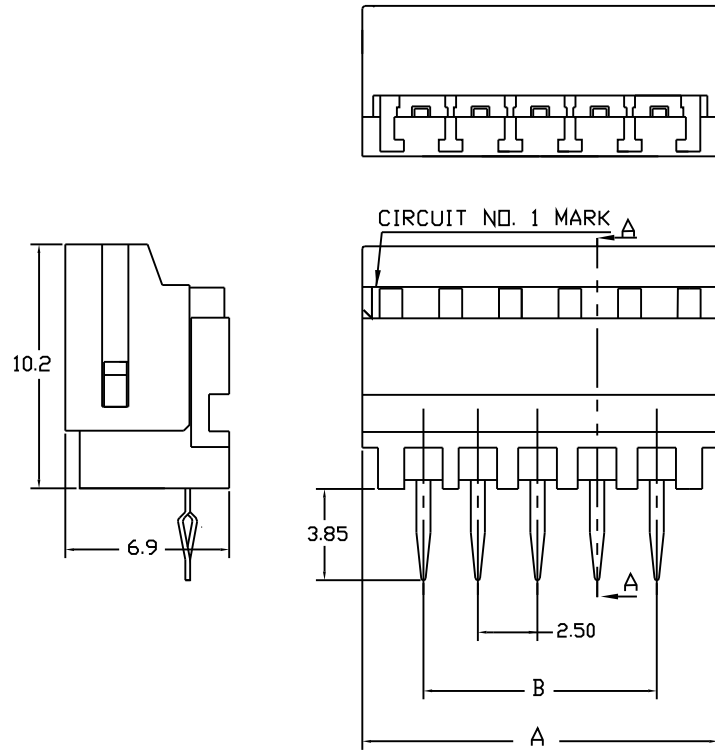

CKT	PART NO.	DIM.A	DIM.B
2	WT-DZ-02	8.10	2.50
3	WT-DZ-03	10.60	5.00
4	WT-DZ-04	13.10	7.50
5	WT-DZ-05	15.60	10.00
6	WT-DZ-06	18.10	12.50
7	WT-DZ-07	20.60	15.00
8	WT-DZ-08	23.10	17.50
9	WT-DZ-09	25.60	20.00
10	WT-DZ-10	28.10	22.50
11	WT-DZ-11	30.60	25.00
12	WT-DZ-12	33.10	27.50
13	WT-DZ-13	35.60	30.00
14	WT-DZ-14	38.10	32.50
15	WT-DZ-15	40.60	35.00
16	WT-DZ-16	43.10	37.50
17	WT-DZ-17	45.60	40.00
18	WT-DZ-18	48.10	42.50
19	WT-DZ-19	50.60	45.00
20	WT-DZ-20	53.10	47.50
21	WT-DZ-21	55.60	50.00
22	WT-DZ-22	58.10	52.50
23	WT-DZ-23	60.60	55.00
24	WT-DZ-24	63.10	57.50
25	WT-DZ-25	65.60	60.00

CABLE DIMENSION

PART NO. WT-DZ-xx		CHECKED BY CY		TOLERANCES ARE .X ± 0.2 .XX ± 0.1 .XXX ± AWG	DESCRIP TION: WIRE TRAP PITCH 2.50mm, VERTICAL
DWG NO. WT-DZ-xx		DRAWING BY			
FILE NO.		PROJECTION		AREA	REVISIONS
UNIT / mm	SCALE 1:1			HK	DATE