

- NOTES:  
 1. MATERIAL:  
 1.1 HOUSING: HALOGEN FREE PLASTIC,UL94V-0.  
 1.2 CONTACT: COPPER ALLOY  
 2.CONTACT:  
 L:50U" NICKEL OVERALL,  
 120U" MIN. LEAD-FREE(PURE TIN).  
 1:50U" NICKEL OVERALL,  
 GOLD FLASH OVER ALL(1U" MIN).  
 N:50U" NICKEL OVERALL,  
 120U" MIN. PURE TIN(MATT TIN) ALLOVER .  
 3. REFLOW SOLDER CAPABLE TO 260°C

ZHQ-VC-xx-LF  
 LEADFREE  
 02~09WAY  
 RoHS Compliant

CKT	Dim A	Dim B
2	1.5	4.3
3	3.0	5.8
4	4.5	7.3
5	6.0	8.8
6	7.5	10.3
7	9.0	11.8
8	10.5	13.3
9	12.0	14.8

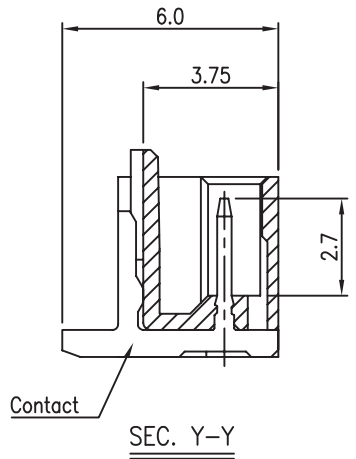
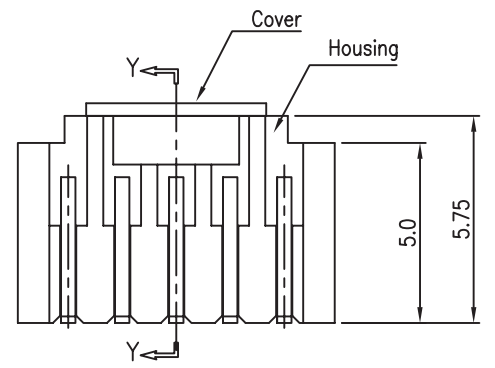
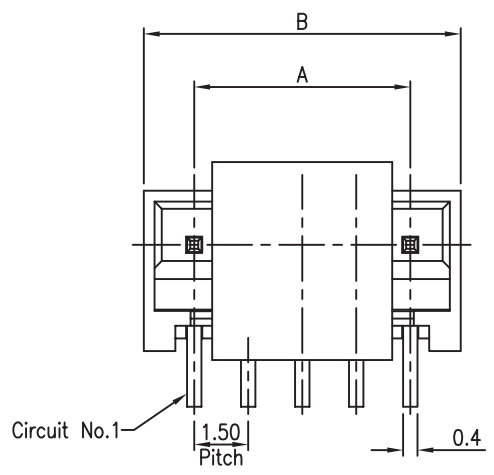
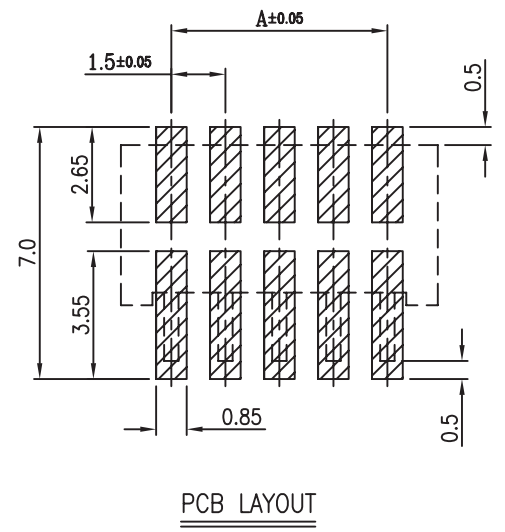

PART NO. ZHQ-VC-xx		CHECKED BY CY		TOLERANCES ARE .X±0.2 .XX± .XXX± AWG	DESCRIPTION: 1.5mm WTB Header SMT Vertical Type	AREA	REVISIONS	HK	DATE
DWG NO. ZHQ-VC-xx		DRAWING BY							
FILE NO.		PROJECTION							
UNIT / mm	SCALE 1:1								