

This document is the property of Targ Yu Enterprise and is delivered on the express condition that it is not to be disclosed, reproduced or used, in whole or in part, for manufacture or sale by anyone other than Targ Yu Enterprise without its prior consent, and that no right is granted to disclose or to use any information in this document.

# Engineer Drawing

REV	ECN NO.	DESCRIPTION	DATE	APP'D
A/0		RELEASE TO PRODUCTION	04/18/11	Paul

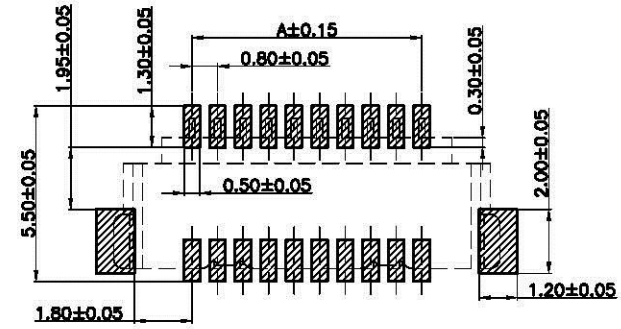
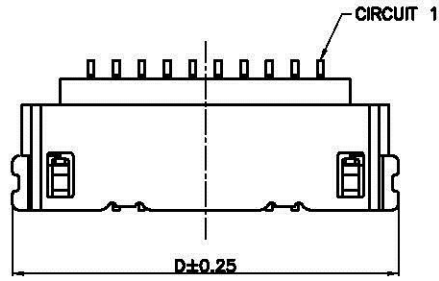

P.C.B. Layout

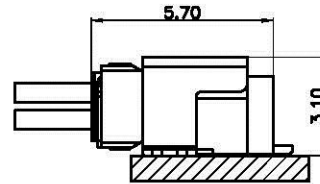
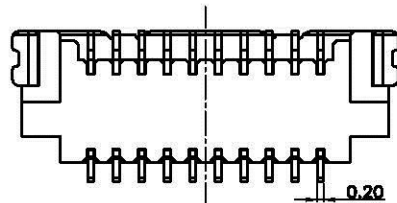
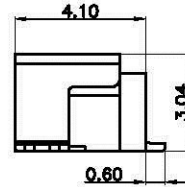
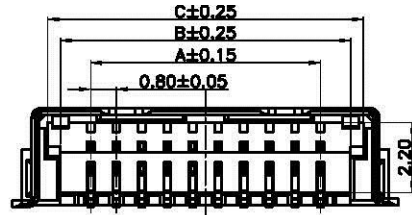

Mating Condition (REF.)

PIN	DIM. (mm)			
	A	B	C	D
2x05	3.20	5.10	5.90	8.10
2x10	7.20	9.10	9.90	12.10
2x15	11.20	13.10	13.90	16.10
2x20	15.20	17.10	17.90	20.10

**NOTES:**

- MATERIAL**  
INSULATION: LCP UL 94V-0 (BLACK)  
CONTACT: COPPER ALLOY  
SOLDER TAB: COPPER ALLOY/FINISH REFERENCE CONTACT
- CONTACT FINISH:** (VOID)--60u" TIN-PLATED OVER NICKEL  
GO--GOLD FLASH OVER NICKEL  
G\*--\*u" GOLD PLATED OVER NICKEL
- MATES WITH:** TU0803 SERIES DUAL ROW HOUSING
- PACKING:** 3,000 PCS/TAPE REEL
- ORDERING CODE:** TU0803WNR-2xNPS-\*--NL-A



<b>TOLERANCE</b> X. ±0.30 X.X ±0.25 X.XX ±0.15 X.XXX ±0.08 ANGULA 3° UNLESS OTHERWISE SPECIFIED	<b>APPROVALS</b>		<b>DATE</b>	 www.allconnectors.de Tel: 0049 201 2009505 20094 Hildesheim - Germany info@allconnectors.de Fax: 0049 201 2009504 Kellernstraße 25	
	DRAWN	<i>Peng Pai</i>	04/18/11'		
	CHK'D	<i>Paul Chen</i>	04/18/11'	<b>PART NO.</b> TU0803WNR-2xNPS-*--NL-A <b>TITLE:</b> WIRE TO BOARD, RECEPTACLE, PITCH 0.80mm, DUAL ROW, RIGHT ANGLE, SMT TYPE, ASSEMBLY	
	APP'D	<i>Wayne Lai</i>	04/18/11'		
<b>DRAWING NO.</b> EN-TU0803WNR-2xNPS-*--NL-A		<b>SIZE:</b> A4 		<b>SHEET 1 OF 3</b> <b>REV. A/0</b>	

This document is the property of Targ Yu Enterprise and is delivered on the express condition that it is not to be disclosed, reproduced or used, in whole or in part, for manufacture or sale by anyone other than Targ Yu Enterprise without its prior consent, and that no right is granted to disclose or to use any information in this document.

# Engineer Drawing

REV	ECN NO.	DESCRIPTION	DATE	APP'D
A/0		RELEASE TO PRODUCTION	04/18/11	Paul

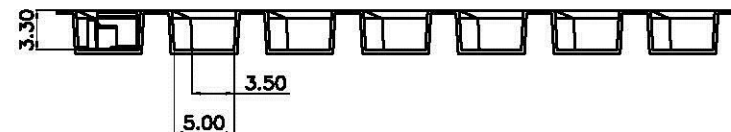
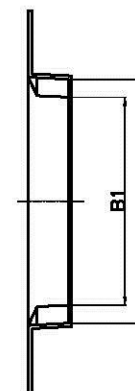
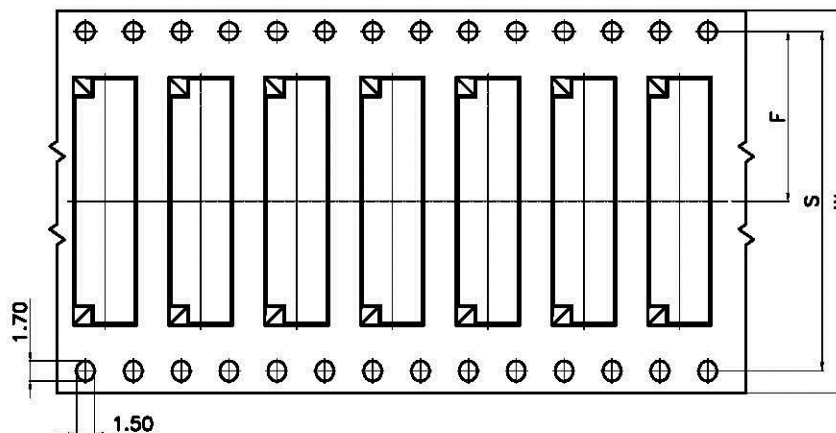
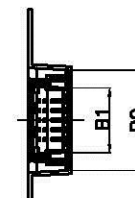
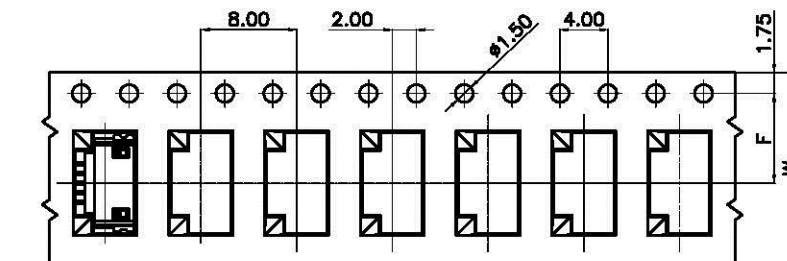
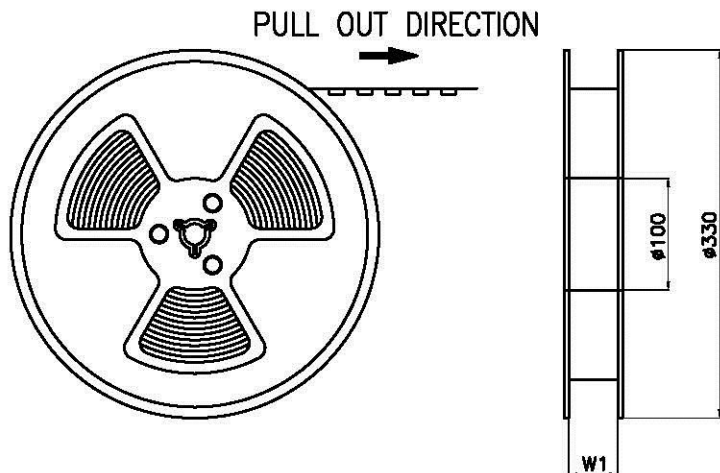

## NOTES:

1. 10 SPROCKET HOLE PITCH CUMULATIVE TOLERANCE  $\pm 0.20$  .
2. CARRIER CAMBER IS WITHIN 1 mm IN 250 mm.
3. MATERIAL : BLACK CONDUCTIVE POLYSTYRENE ALLOY.(UP-5000)
4. ALL DIMENSIONS MEET EIA-481-C REQUIREMENTS.
5. THICKNESS :  $0.30 \pm 0.05$ mm.
6. COMPONENT LOAD PER 13" REEL : 3000 PCS.

PIN	DIM. (mm)				
	B0	F	W	W1	S
2x05	8.40	7.50	16.00	17.50	-
2x10	12.40	11.50	24.00	25.50	-
2x15	16.40	11.50	24.00	25.50	-
2x20	20.40	14.20	32.00	33.50	28.40

TOLERANCE	
X.	$\pm 0.30$
X.X	$\pm 0.25$
X.XX	$\pm 0.15$
X.XXX	$\pm 0.08$
ANGULA	3'
UNLESS OTHERWISE SPECIFIED	

APPROVALS		DATE
DRAWN	<i>Peng Pai</i>	04/18/11'
CHK'D	<i>Paul Chen</i>	04/18/11'
APP'D	<i>Wayne Lai</i>	04/18/11'
UNITS	mm	SCALE 1:1
		SIZE: A4

**All Connectors**

www.allconnectors.de  
Tel.: 0049 711 7009503  
70794 Filderstadt Germany

info@allconnectors.de  
Fax: 0049 711 7009504  
Kettlerstr. 25

PART NO.  
TU0803WNR-2xNPS-\*--NL-A

DRAWING NO.  
EN-TU0803WNR-2xNPS-\*--NL-A

TITLE:  
WIRE TO BOARD, RECEPTACLE,  
RIGHT ANGLE, SMT TYPE,  
ASSEMBLY

SHEET 2 OF 3

REV. A/0

This document is the property of Targ Yu Enterprise and is delivered on the express condition that it is not to be disclosed, reproduced or used, in whole or in part, for manufacture or sale by anyone other than Targ Yu Enterprise without its prior consent, and that no right is granted to disclose or to use any information in this document.

# Engineer Drawing

REV	ECN NO.	DESCRIPTION	DATE	APP'D
A/0		RELEASE TO PRODUCTION	04/18/11	Paul

PACKING MATERIAL	
PART NAME	DIM. (mm)
REEL	Ø330*(W+0.5)
CARTON	350*350*340

PACKING CAPACITY			
PART NO.	PCS/RE	RE/BC	PCS/BC
TU0803WNR-2x05S*-NL-A	2,500PCS/RE	14RE/BC	35,000PCS/BC
TU0803WNR-2x10S*-NL-A	2,500PCS/RE	10RE/BC	25,000PCS/BC
TU0803WNR-2x15S*-NL-A	2,500PCS/RE	10RE/BC	25,000PCS/BC
TU0803WNR-2x20S*-NL-A	2,500PCS/RE	8RE/BC	20,000PCS/BC

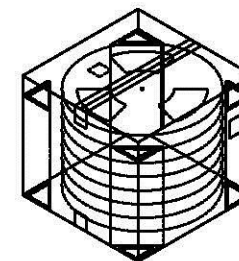
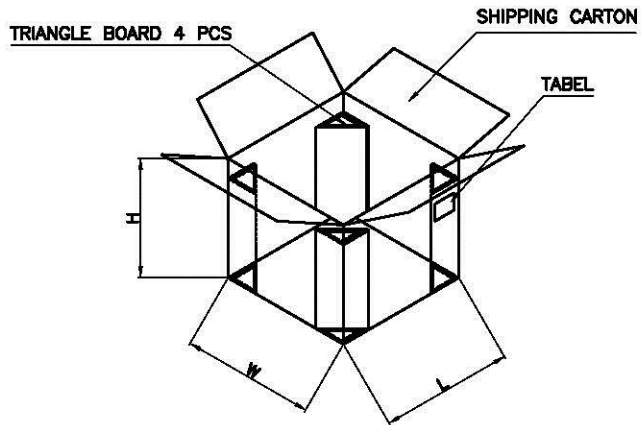
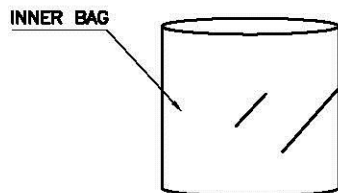
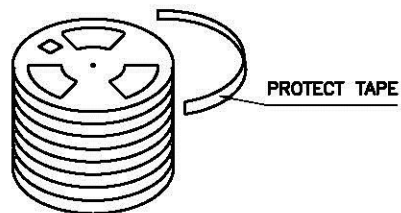
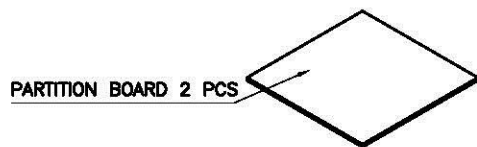

TOLERANCE	
X.	±0.30
X.X	±0.25
X.XX	±0.15
X.XXX	±0.08
ANGULA	3'
UNLESS OTHERWISE SPECIFIED	

APPROVALS		DATE
DRAWN	<i>Peng Poi</i>	04/18/11'
CHK'D	<i>Paul Chen</i>	04/18/11'
APP'D	<i>Wayne Lai</i>	04/18/11'
UNITS	mm	SCALE 1:1
		SIZE: A4

**All Connectors**  
 www.allconnectors.de  
 Tel.: 0049 711 7009503  
 20784 Eilendorf, Germany

info@allconnectors.de  
 Fax: 0049 711 7002504  
 Kethenmühle, 21

PART NO. TU0802WNR-2xNPS-x-NL	TITLE: WIRE TO BOARD, RECEPTACLE, PITCH 0.80mm, DUAL ROW, RIGHT ANGLE, SMT TYPE, ASSEMBLY
DRAWING NO. EN-TU0802WNR-2xNPS-x-NL	

SHEET 3 OF 3

REV. A/0