

This document is the property of Targ Yu Enterprise and is delivered on the express condition that it is not to be disclosed, reproduced or used, in whole or in part, for manufacture or sale by anyone other than Targ Yu Enterprise without its prior consent, and that no right is granted to disclose or to use any information in this document.

Engineer Drawing

REV	ECN NO.	DESCRIPTION	DATE	APP'D
A/0		NEW DRAWING	04/19/13	Paul
A/1		UPDATE DRAWING	05/17/13	Paul
A/2		UPDATE DRAWING	09/12/13	Paul

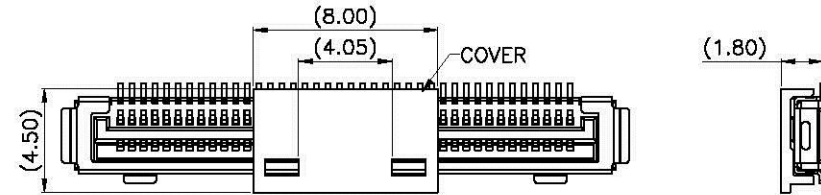
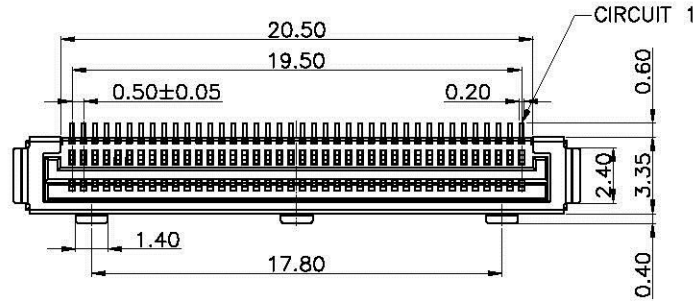

PICK AND PLACE AREA

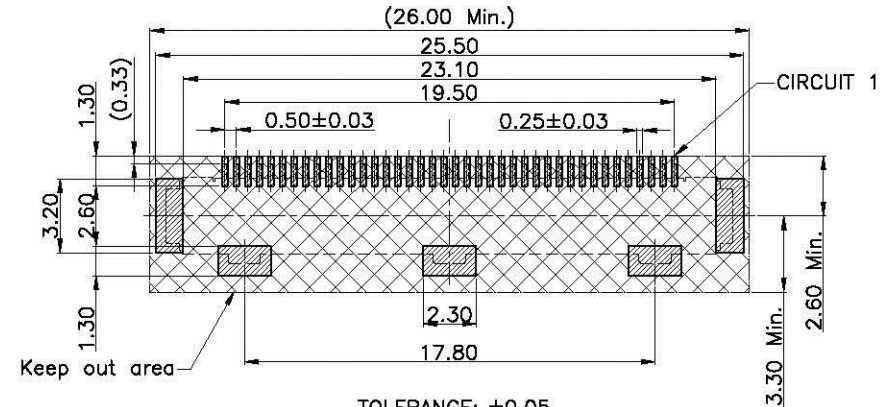
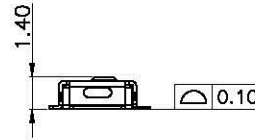
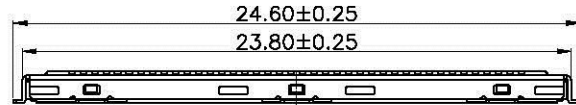

TOLERANCE: ± 0.05
RECOMMENDED P.C.B. Layout
TOP VIEW

NOTES:

- MATERIAL
INSULATION(HALOGEN FREE): LCP, UL94V-0 (BLACK)
CAP(HALOGEN FREE): LCP, UL94V-0 (BLACK)
CONTACT: COPPER ALLOY, $t=0.10\text{mm}$
SHELL: COPPER ALLOY, $t=0.15\text{mm}$ / TIN-PLATED OVER NICKEL
- CONTACT FINISH: (VOID)--GOLD FLASH OVER NICKEL
G*--GOLD *u" OVER NICKEL
- MATES WITH: TD0502 SERIES HOUSING
- ORDERING CODE: TD0502WNV-40S-*--NL-A

PIN NO. | TAPE REEL PACKING
SMT-TYPE | HALOGEN FREE
FINISH SEE NOTE 2

TOLERANCE		APPROVALS	DATE	All Connectors	
X.X	± 0.25	DRAWN	09/12/13'	www.allconnectors.de Tel: 0049 711 7009503 70754 Filberstadt - Germany info@allconnectors.de Fax: 0049 711 7009504 Kellenbergstr. 25	
		CHK'D			
X.XX	± 0.15	APP'D	09/12/13'	PART NO.	TITLE: WIRE TO BOARD, RECEPTACLE, PITCH 0.50mm, VERTICAL SMT TYPE, ASSEMBLY
ANGULA	3'	UNITS mm	SCALE 1:1	DRAWING NO.	
UNLESS OTHERWISE SPECIFIED		SIZE: A4	SIZE: A4	EN-TD0502WNV-40S-*--NL-A	SHEET 1 OF 3

REV. A/2

This document is the property of Targ Yu Enterprise and is delivered on the express condition that it is not to be disclosed, reproduced or used, in whole or in part, for manufacture or sale by anyone other than Targ Yu Enterprise without its prior consent, and that no right is granted to disclose or to use any information in this document.

Engineer Drawing

REV	ECN NO.	DESCRIPTION	DATE	APP'D
A/0		NEW DRAWING	04/19/13	Paul
A/1		UPDATE DRAWING	05/17/13	Paul
A/2		UPDATE DRAWING	09/12/13	Paul

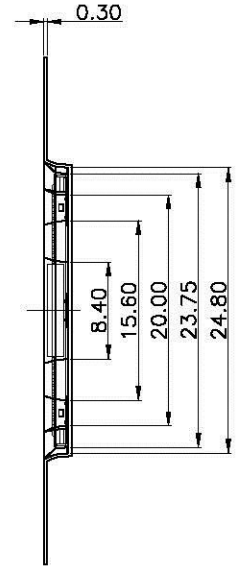
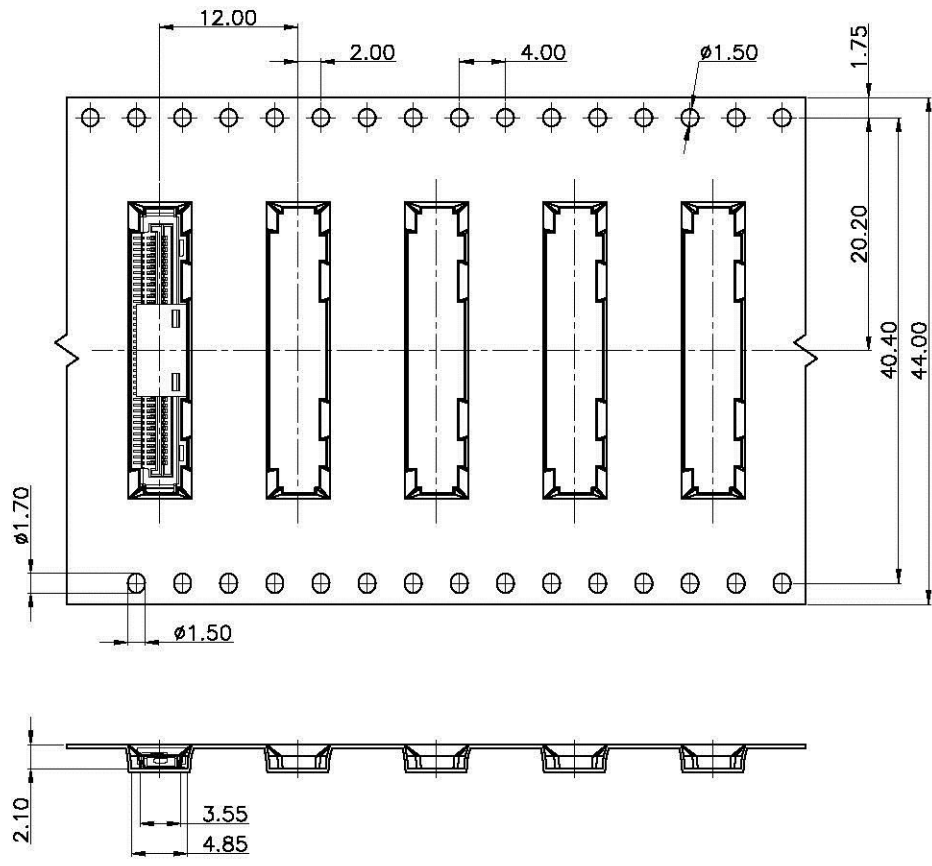
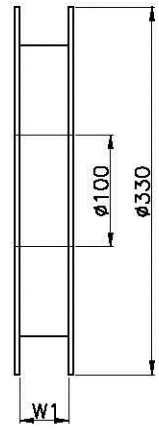
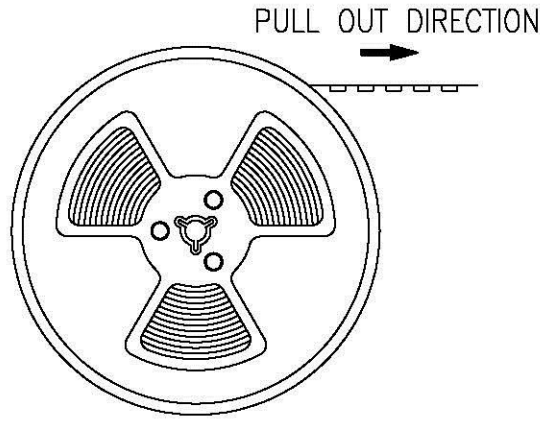

- NOTES:
- 10 SPROCKET HOLE PITCH CUMULATIVE TOLERANCE ± 0.20
 - CARRIER CAMBER IS WITHIN 1 mm IN 250 mm
 - MATERIAL : BLACK CONDUCTIVE POLYSTYRENE ALLOY.(UP-5000)
 - ALL DIMENSIONS MEET EIA-481-C REQUIREMENTS
 - THICKNESS : 0.40 ± 0.05 mm
 - COMPONENT LOAD PER 13" REEL : 2000 PCS

TOLERANCE		APPROVALS		DATE	All Connectors	
X.X	± 0.25	DRAWN <i>Sivan Kong</i>		09/12/13'	www.allconnectors.de Tel.: 0049 711 7009503 70798 Ellersbachtal - Germany	
X.XX	± 0.15	CHK'D <i>Paul Chen</i>		09/12/13'	info@allconnectors.de Fax: 0049 711 7009504 Kette Markt, 35	
ANGULA	3'	APP'D <i>Wayne Lai</i>		09/12/13'	PART NO. TD0502WNV-40S-*--NL-A	
UNLESS OTHERWISE SPECIFIED		UNITS mm		SCALE 1:1	SIZE: A4	TITLE: WIRE TO BOARD, RECEPTACLE, PITCH 0.50mm, VERTICAL SMT TYPE, ASSEMBLY



www.allconnectors.de
Tel.: 0049 711 7009503
70798 Ellersbachtal - Germany

info@allconnectors.de
Fax: 0049 711 7009504
Kette Markt, 35

PART NO.
TD0502WNV-40S-*--NL-A

DRAWING NO.
EN-TD0502WNV-40S-*--NL-A

SHEET 2 OF 3

REV. A/2

This document is the property of Targ Yu Enterprise and is delivered on the express condition that it is not to be disclosed, reproduced or used, in whole or in part, for manufacture or sale by anyone other than Targ Yu Enterprise without its prior consent, and that no right is granted to disclose or to use any information in this document.

Engineer Drawing

REV	ECN NO.	DESCRIPTION	DATE	APP'D
A/0		NEW DRAWING	04/19/13	Paul
A/1		UPDATE DRAWING	05/17/13	Paul
A/2		UPDATE DRAWING	09/12/13	Paul

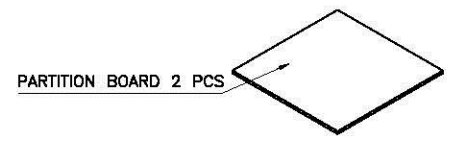

PACKING MATERIAL	
PART NAME	DIM.(mm)
REEL	ø330*(W+0.5)
CARTON	350*350*340

PACKING CAPACITY			
PART NO.	PCS/RE	RE/BE	PCS/BC
TD0502WNV-40S-*--NL-A	2,000 PCS/RE	6 RE/BE	12,000 PCS/BC

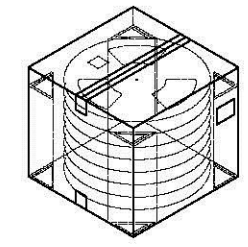
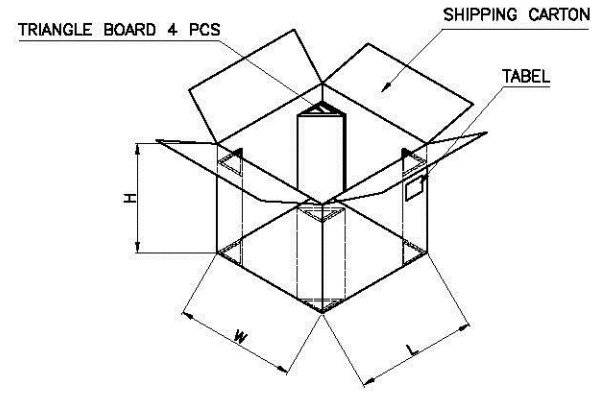
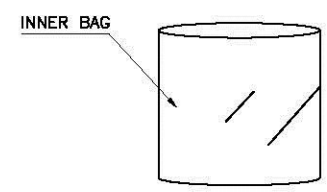
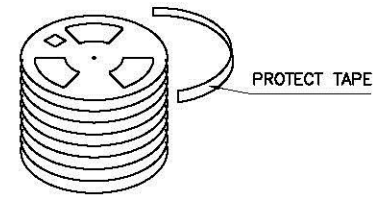
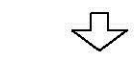

TOLERANCE X.X ±0.25 X.XX ±0.15 ANGULA 3° UNLESS OTHERWISE SPECIFIED	APPROVALS		DATE	 <small>www.allconnectors.de Tel: 0049 711 700503 70794 Ellersstr. 25 - Germany</small> <small>info@allconnectors.de Fax: 0049 711 700504 Kette merstr. 25</small>	
	DRAWN	<i>Sivan Kong</i>	09/12/13'		
	CHK'D	<i>Paul Chen</i>	09/12/13'	PART NO.	TITLE: WIRE TO BOARD, RECEPTACLE, PITCH 0.50mm, VERTICAL SMT TYPE, ASSEMBLY
	APP'D	<i>Wayne Lai</i>	09/12/13'	TD0502WNV-40S-*--NL-A DRAWING NO. EN-TD0502WNV-40S-*--NL-A	
	UNITS mm	SCALE 1:1	SIZE: A4	SHEET 3 OF 3	REV. A/2