

- NOTE :
1. MAXIMUM ELECTRIC CURRENT : 

A.W.G.	16	14	
AMP.	10	15	
  2. MAXIMUM ELECTRICAL RATING : 105°C 600 VOLTS MAX.
  3. INSULATION MATERIAL : NYLON
  4. INSULATION COLOR : BLUE
  5. TERMINAL MATERIAL : BRASS
  6. WIRE RANGE : 16-14 A.W.G. ( 1.5-2.5 mm<sup>2</sup> )
  7. NEMA TAB : 0.020 inch \* 0.187 inch ( 0.5 mm \* 4.75 mm )
  8. TERMINAL SURFACE TREATMENT : TIN PLATED
  9. TERMINAL THICKNESS : 0.35 mm

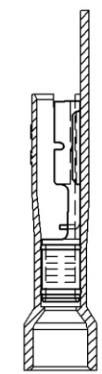
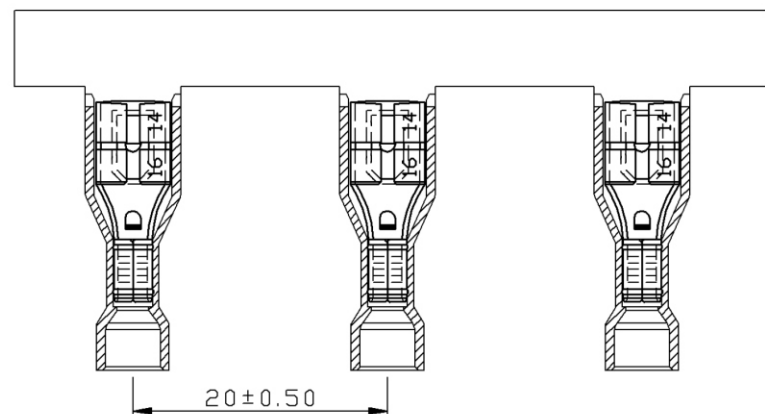
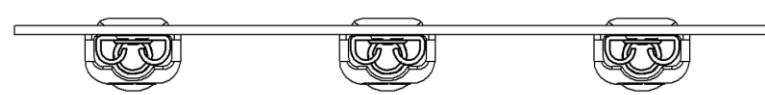

Q187-FT5NFDR-14-LF  
LEADFREE  
RoHS Compliant

<p style="font-size: 8px; margin-top: 5px;">www.allconnectors.eu   info@allconnectors.eu Tel. +49 (0)711 / 358 110 20   Fax +49 (0)711 / 358 110 25</p>	PART NO. Q187-FT5NFDR-14		CHECKED BY CY	TOLERANCES ARE	DESCRIP TION:			
	DWG NO. Q187-FT5NFDR-14							
	FILE NO.		PROJECTION					
	UNIT / mm	SCALE 1:1						