

類型	Dim.D	NOTE
acetate tape	3mm	03~04PIN
	5.1mm	05~09PIN
	10mm	10~40PIN
cap	3mm	3pin適用
	4.2mm	4pin以上適用

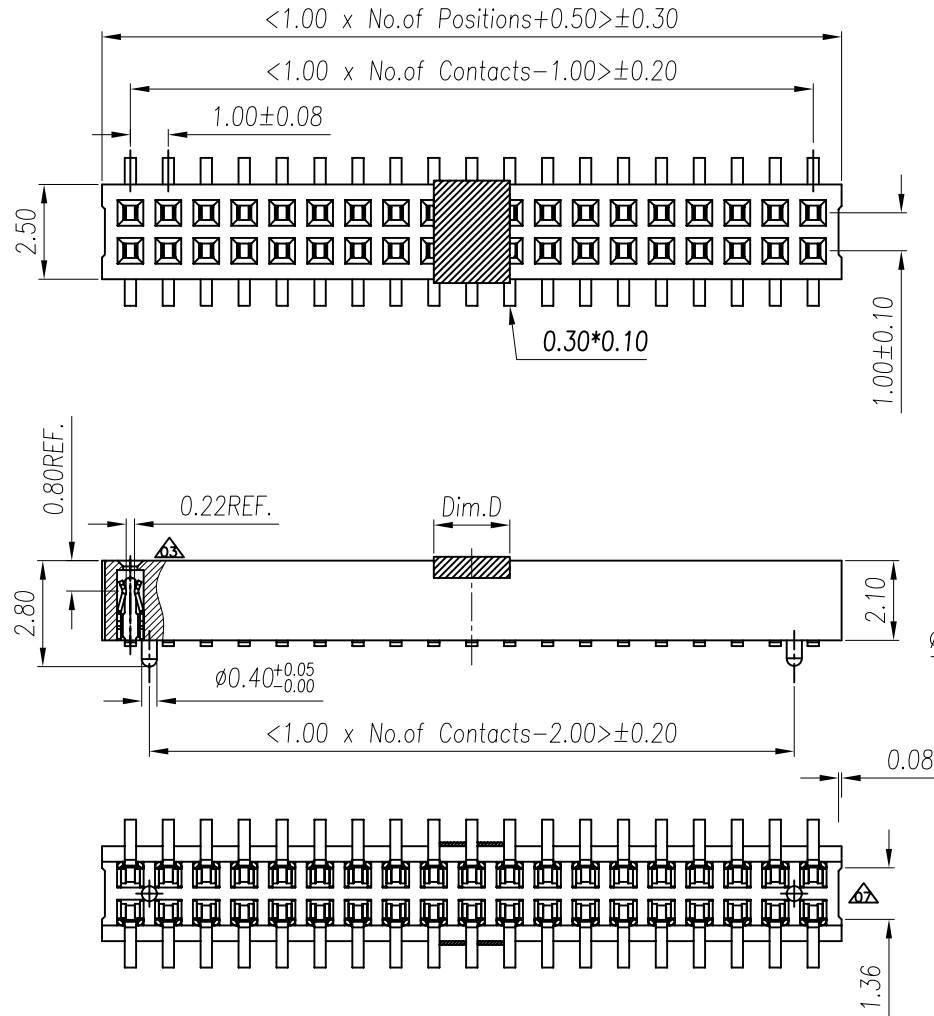
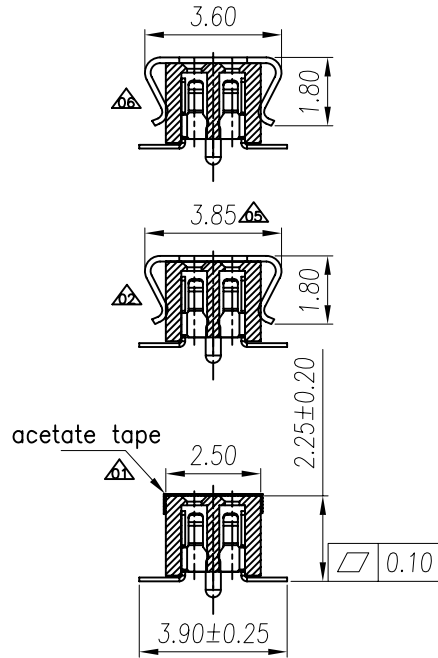

Specifications

Current Rating: 1.0Amp
 Insulation Resistance: 500M ΩMin.
 Dielectric Withstanding: 200VAC
 Contact Resistance: 20mΩ Max.
 Operating Temperature: -40°C to +105°C
 Max Process Temp: 230°C for 30~60 sec.
Materials
 Contact Material: Phosphor Bronze
 Insulator Material: Polyester, UL 94V-0 LCP
 All materials must meet Greenconn requirement for environment protection

RECOMMENDED P.C.B LAYOUT FOR BOTTOM ENTRY

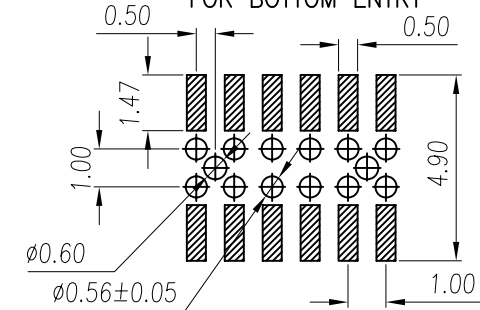

RECOMMENDED P.C.B LAYOUT FOR TOP ENTRY

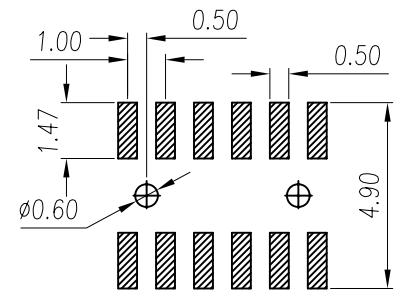

Ordering Information

HFGDSV1 - XX XX XXX L X

No. of Pins Per Row: 02-40
 Standard Plating: 01=Gold Flash, 02=Gold 3U", 11=Tin, XX=Select Plating
 Pin Length: 001=W/2.9
 Material: L=LCP, T=6T
 Packing: T=Tube, TP=Tape+Reel

GENERAL TOLERANCE	ANGLE TOLERANCE	DESIGN	DATE
X. ±0.38 .XX ±0.25 .XXX ±0.13	X° ±5° .X° ±2° .XX° ±1° .XXX° ±0.5°	Andy2005.08.12	
UNIT:mm	SCALE: 1:1	CHECK	DATE
A4	SHEET: 1 of 1	APPRO.	DATE

All Connectors www.allconnectors.eu info@allconnectors.eu Tel. +49 (0)711 / 358 110 20 Fax +49 (0)711 / 358 110 25	
FILE NAME (品名)	1.0mm Female Header SMT Type
PART NO (料号)	HFGDSV1-XXXXXXXL
DRAWING NO.(图号)	HFGDSV1-01
	REV.A0