

**NOTES:**

1. MATERIAL:  
CONTACT:PHOSPHOR BRONZE  
SHELL-STEEL,NICKEL PLATED  
HOUSING: THERMOPLASTIC, NYLON
2. ENVIRONMENTAL:TEMPERATURE RANGE -20°C TO +85°C
3. ELECTRICAL:  
RATED:1.5A @ 40V AC(ms)  
CONTACT RESISTANCE:20 MILLIOHMS MAXIMUM  
INSULATION RESISTANCE: 1G OHMS MINIMUM  
DIELECTRIC WITHSTANDING VOLTAGE:500V AC(ms)
4. MECHANICAL:  
MATING FORCE: 10 LB.(4.5KG) MAXIMUM  
UNMATING FORCE:2.2LB.(1Kg) MINIMUM  
8.8LB.(4Kg) MAXIMUM

DVI-SDN-24+1-LF  
LEADFREE

RoHS Compliant

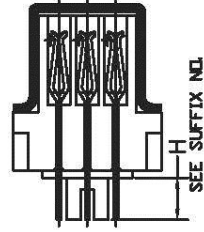
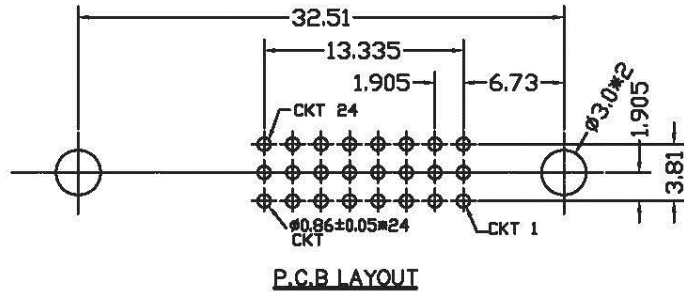

A-A SECTION

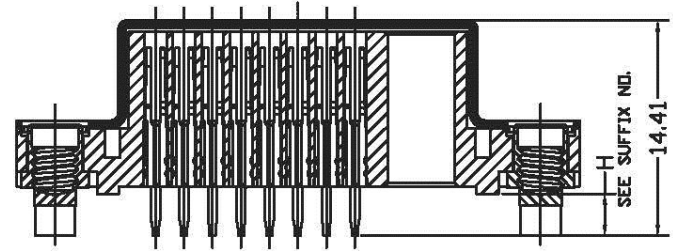

B-B SECTION

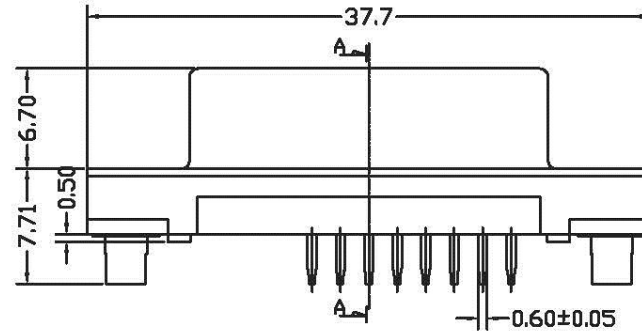
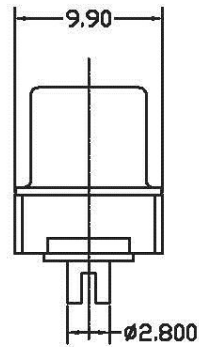
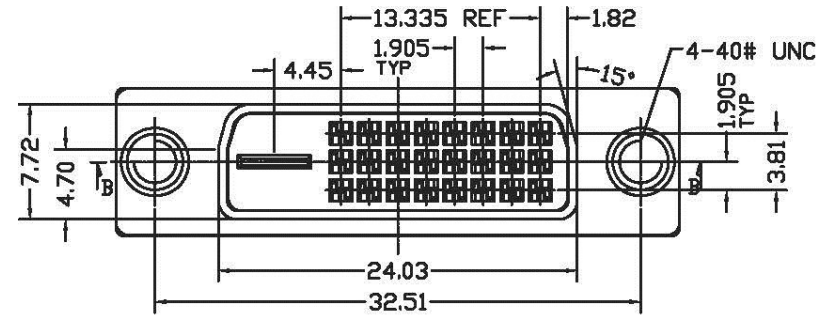

**MORETHANALL**  
CONNECTORS  
ASSEMBLIES

煜倫股份有限公司

PART NO. DVI-SDN-24+1

DWG NO. DVI-SDN-24+1

FILE NO.

UNIT / mm

SCALE 1:1

CHECKED BY CY

DRAWING BY

PROJECTION

TOLERANCES ARE

.X ± 0.2  
.XX ±  
.XXX ±  
AWG

DESCRIPTION: DVI 24+1 VERTICAL FEMALE CONN.(ASSEMBLY DRAWING)

AREA	REVISIONS	HK	DATE
------	-----------	----	------