

	∅F
W/ SR	∅6.5
W/O SR	∅3.0~∅9.5

REV.	DESCRIPTION	DRAWN	CHECKED	APPROVED
A	NEW RELEASE	YCH 03/22/11'	~	

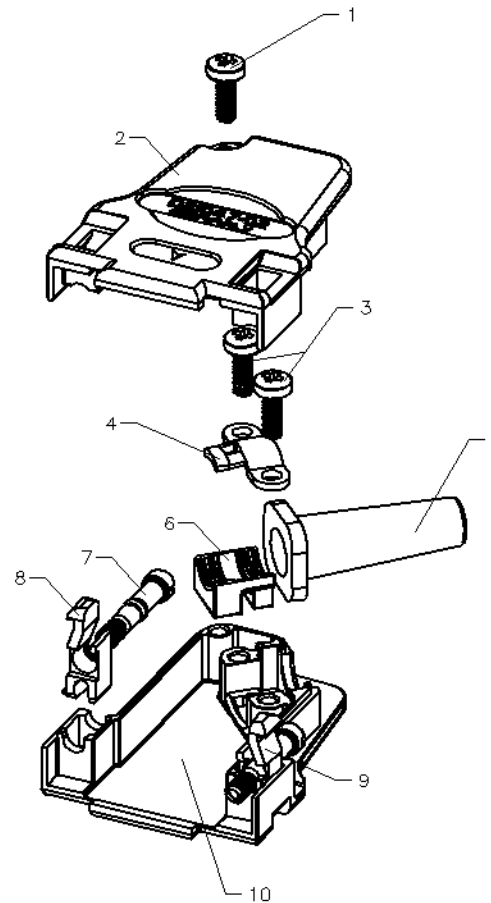
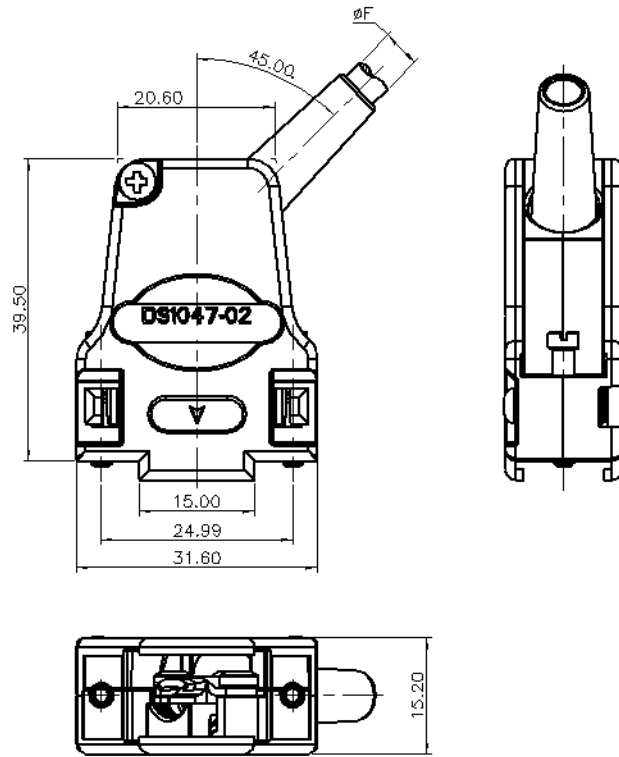

NOTES:

1. PART NUMBER CODE:

DS1047-02 - 09 X X X

- SR Support
- S: W/ SR
- X: W/O SR
- Packing type
- 1: Mix packing
- 2: Separation packing
- Cover Material
- M: Metal(Znic alloy)
- Positions
- 09: 9pin

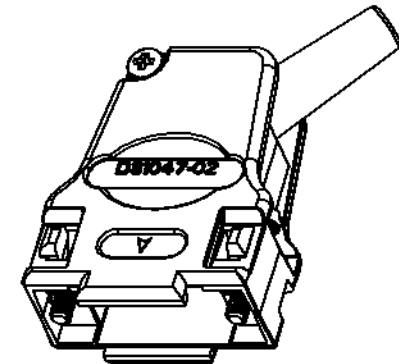

BOM LIST			
ITEM	PART NAME	Q'ty	NOTES
1	SCREW M2.5*8	1	M2.5
2	METAL HOOD-1	1	Znic alloy
3	SCREW M2.5*6	2	M2.5
4	WASHER	1	
5	SR	1	
6	STRAIN RELIEF	1	
7	BOLT	2	UNC 4-40
8	LATCH-1	1	
9	LATCH-2	1	
10	METAL HOOD-2	1	Znic alloy

GENERAL TOLERANCE		ANGLE TOLERANCE		PROJECTION		TITLE	D-SUB 9pin Metal Hoods Large Angled Cable Outlet
X.	±0.60	X.	±5°	UNITS	mm	SERIES	DS1047-02 SERIES
.X	±0.38	.X	±3°	SHEET SIZE	A4		
.XX	±0.25	.XX	±2°				
DRAWING TYPE		CUSTOMER		 www.allconnectors.eu info@allconnectors.eu Tel. +49 (0)711 / 358 110 20 Fax +49 (0)711 / 358 110 25			
SCALE		1:1					
DRAWING NO.		C-DS1047-02-09XXX					

		∅F
TYPE A	W/ SR	∅8.5
	W/O SR	∅3.0~∅9.5
TYPE B	W/ SR	∅9.0
	W/O SR	∅8.5~∅12.5

REV.	DESCRIPTION	DRAWN	CHECKED	APPROVED
A	NEW RELEASE	YCH 03/22/11'	~	

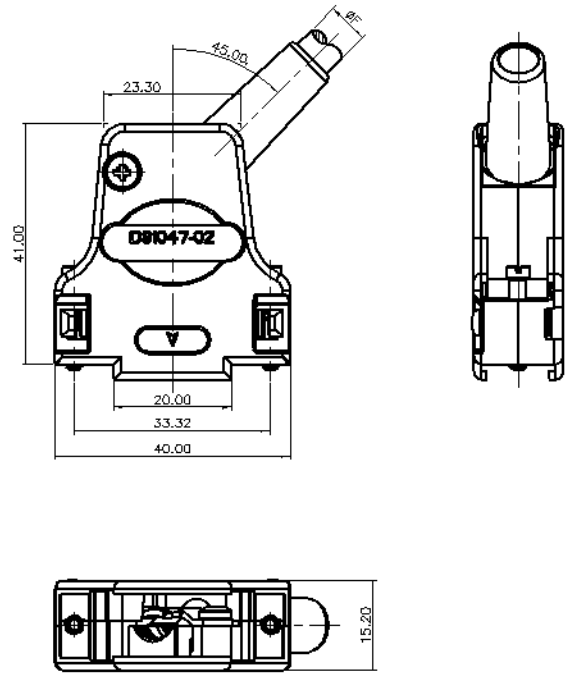

NOTES:
 1. PART NUMBER CODE:
 DS1047-02 - 15 X X X X

- SR Support
- S: W/ SR
- X: W/O SR
- Type Support
- A: Type A
- B: Type B
- Packing type
- 1: Mix packing
- 2: Separation packing
- Cover Material
- M: Metal(Znic alloy)
- Positions
- 15: 15pin

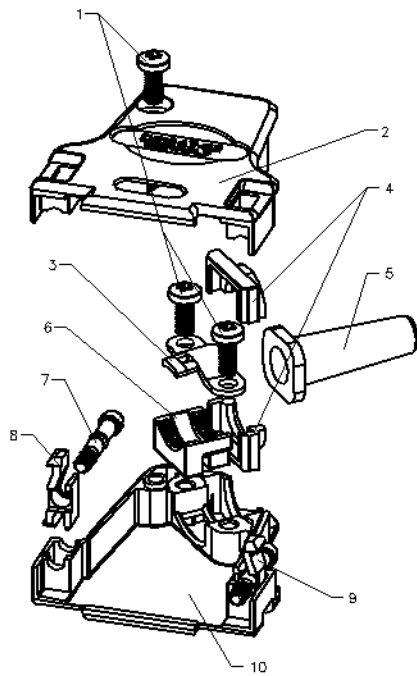

TYPE A

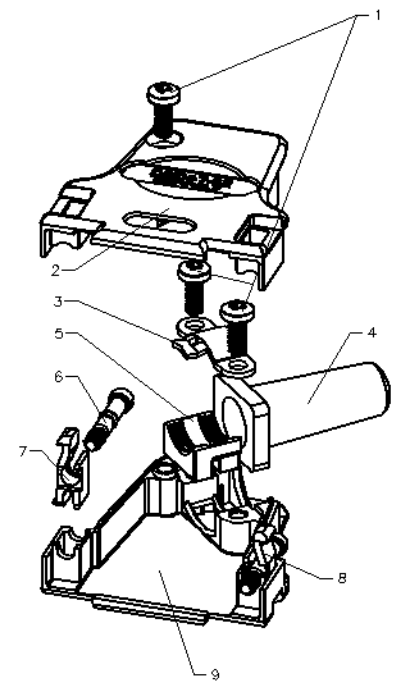

TYPE B

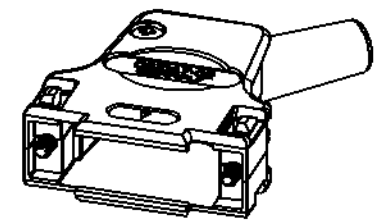

TYPE A BOM LIST			
ITEM	PART NAME	Q'ty	NOTES
1	SCREW	3	M3
2	METAL HOOD-1	1	Znic alloy
3	WASHER	1	
4	CABLE REDUCTION PLATE	2	
5	SR	1	
6	STRAIN RELIEF	1	
7	BOLT	2	UNC 4-40
8	LATCH-1	1	
9	LATCH-2	1	
10	METAL HOOD-2	1	Znic alloy

TYPE B BOM LIST			
ITEM	PART NAME	Q'ty	NOTES
1	SCREW	3	M3
2	METAL HOOD-1	1	Znic alloy
3	WASHER	1	
4	SR	1	
5	STRAIN RELIEF	1	
6	BOLT	2	UNC 4-40
7	LATCH-1	1	
8	LATCH-2	1	
9	METAL HOOD-2	1	Znic alloy

GENERAL TOLERANCE		ANGLE TOLERANCE		PROJECTION	TITLE	D-SUB 15pin Metal Hoods Large Angled Cable Outlet	
X.	±0.60	X.	±5°	mm			
.X	±0.38	.X	±3°	A4	SERIES	DS1047-02 SERIES	
.XX	±0.25	.XX	±2°				
DRAWING TYPE		CUSTOMER					
SCALE	1:1	SHEET	1 OF 1				
DRAWING NO.		C-DS1047-02-15XXXX		www.allconnectors.eu info@allconnectors.eu Tel. +49 (0)711 / 358 110 20 Fax +49 (0)711 / 358 110 25			

		φF
TYPE A	W/ SR	φ8
	W/O SR	φ3.0~φ8.5
TYPE B	W/ SR	φ9.0
	W/O SR	φ8.5~φ12.5

REV.	DESCRIPTION	DRAWN	CHECKED	APPROVED
A	NEW RELEASE	YCH 03/22/11'	~	

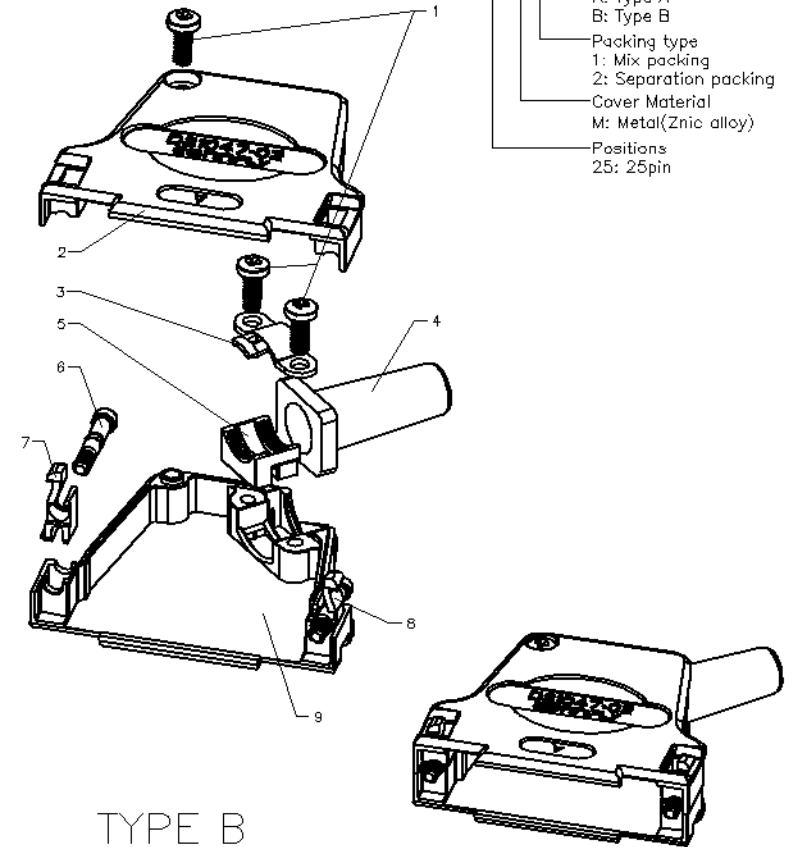
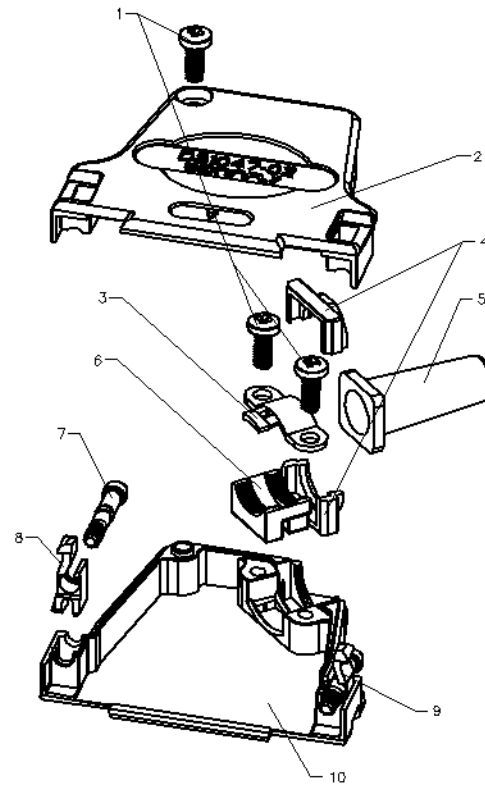
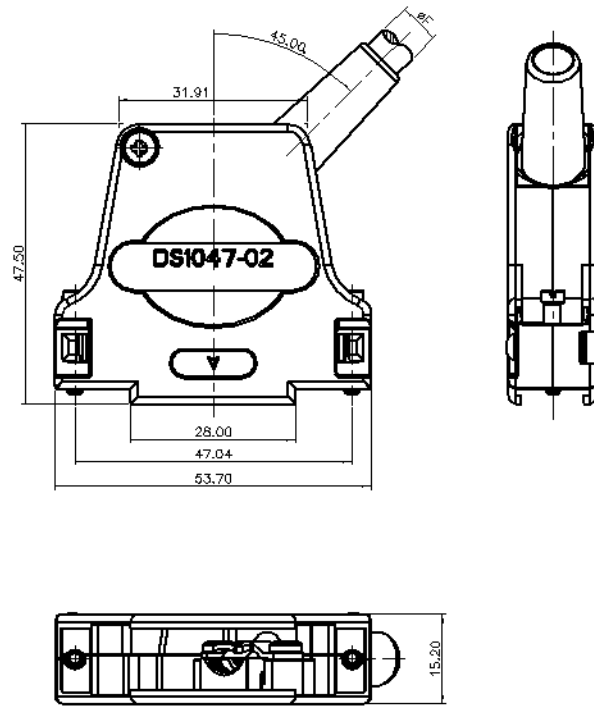

NOTES:
1. PART NUMBER CODE:
DS1047-02 - 25 X X X X

- SR Support
- S: W/ SR
- X: W/O SR
- Type Support
- A: Type A
- B: Type B
- Packing type
- 1: Mix packing
- 2: Separation packing
- Cover Material
- M: Metal(Zinc alloy)
- Positions
- 25: 25pin

TYPE A

TYPE B

TYPE A BOM LIST			
ITEM	PART NAME	Q'ty	NOTES
1	SCREW	3	M3
2	METAL HOOD-1	1	Znic alloy
3	WASHER	1	
4	CABLE REDUCTION PLATE	2	
5	SR	1	
6	STRAIN RELIEF	1	
7	BOLT	2	UNC 4-40
8	LATCH-1	1	
9	LATCH-2	1	
10	METAL HOOD-2	1	Znic alloy

TYPE B BOM LIST			
ITEM	PART NAME	Q'ty	NOTES
1	SCREW	3	M3
2	METAL HOOD-1	1	Znic alloy
3	WASHER	1	
4	SR	1	
5	STRAIN RELIEF	1	
6	BOLT	2	UNC 4-40
7	LATCH-1	1	
8	LATCH-2	1	
9	METAL HOOD-2	1	Znic alloy

GENERAL TOLERANCE		ANGLE TOLERANCE	
X.	±0.60	X.	±5°
.X	±0.38	.X	±3°
.XX	±0.25	.XX	±2°

PROJECTION	TITLE	D-SUB 25pin Metal Hoods Large Angled Cable Outlet	
UNITS	mm	SHEET SIZE	A4
SHEET SIZE	A4	SERIES	DS1047-02 SERIES

DRAWING TYPE	CUSTOMER		
SCALE	1:1	SHEET	1 OF 1
DRAWING NO.	C-DS1047-02-25XXXX		

Allconnectors

www.allconnectors.eu | info@allconnectors.eu
Tel. +49 (0)711 / 358 110 20 | Fax +49 (0)711 / 358 110 25

	øF	
TYPE A	W/ SR	ø9
	W/O SR	ø3.0~ø12.0
TYPE B	W/ SR	ø11.5
	W/O SR	ø12.0~ø15.0

REV.	DESCRIPTION	DRAWN	CHECKED	APPROVED
A	NEW RELEASE	YCH 03/22/11'	~	

NOTES:
1. PART NUMBER CODE:
DS1047-02 - 37 X X X X

- SR Support
- S: W/ SR
- X: W/O SR
- Type Support
- A: Type A
- B: Type B
- Packing type
- 1: Mix packing
- 2: Separation packing
- Cover Material
- M: Metal(Znic alloy)
- Positions
- 37: 37pin

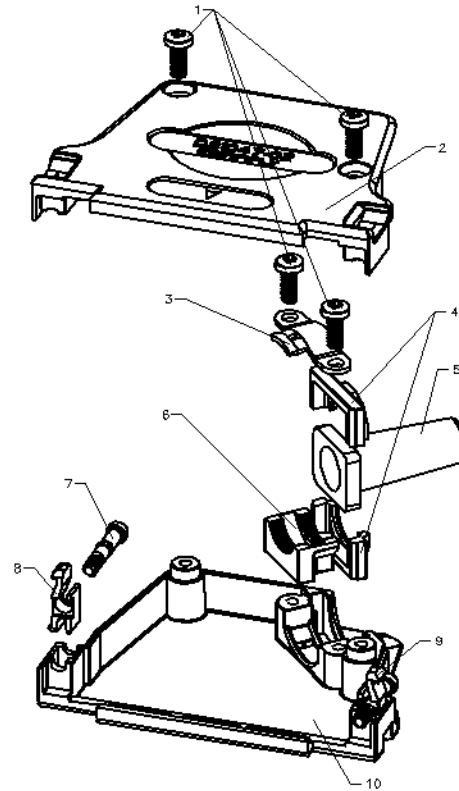
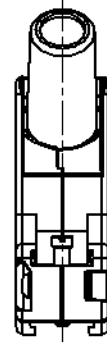
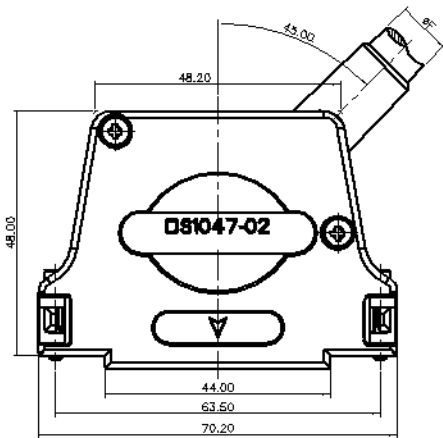

TYPE A

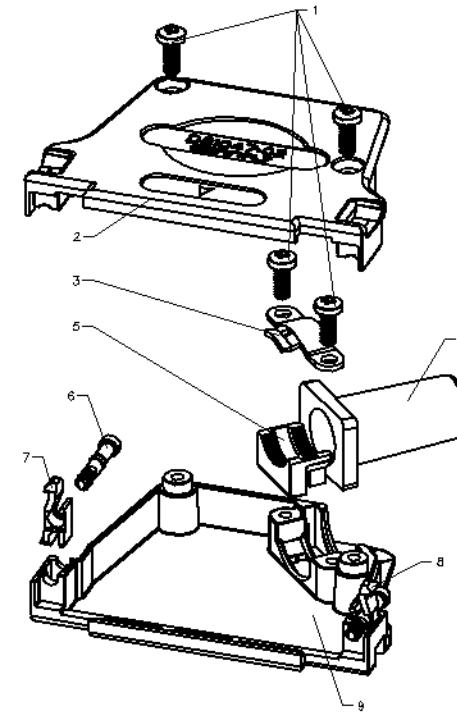

TYPE B

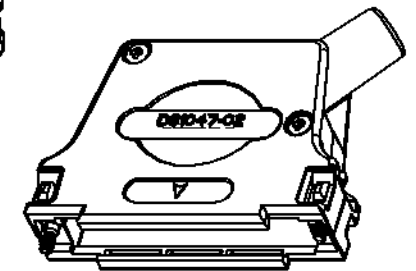

TYPE A BOM LIST			
ITEM	PART NAME	Q'ty	NOTES
1	SCREW	4	M3
2	METAL HOOD-1	1	Znic alloy
3	WASHER	1	
4	CABLE REDUCTION PLATE	2	
5	SR	1	
6	STRAIN RELIEF	1	
7	BOLT	2	UNC 4-40
8	LATCH-1	1	
9	LATCH-2	1	
10	METAL HOOD-2	1	Znic alloy

TYPE B BOM LIST			
ITEM	PART NAME	Q'ty	NOTES
1	SCREW	4	M3
2	METAL HOOD-1	1	Znic alloy
3	WASHER	1	
4	SR	1	
5	STRAIN RELIEF	1	
6	BOLT	2	UNC 4-40
7	LATCH-1	1	
8	LATCH-2	1	
9	METAL HOOD-2	1	Znic alloy

GENERAL TOLERANCE		ANGLE TOLERANCE	
X.	±0.60	X.	±5°
.X	±0.38	.X	±3°
.XX	±0.25	.XX	±2°

PROJECTION	TITLE	D-SUB 37pin Metal Hoods Large Angled Cable Outlet	
UNITS	mm	SHEET SIZE	A4
SHEET SIZE	A4	SERIES	DS1047-02 SERIES

DRAWING TYPE	CUSTOMER		
SCALE	1:1	SHEET	1 OF 1
DRAWING NO.	C-DS1047-02-37XXXX		

Allconnectors

www.allconnectors.eu | info@allconnectors.eu
Tel. +49 (0)711 / 358 110 20 | Fax +49 (0)711 / 358 110 25