

REV.	DESCRIPTION	DRAWN	CHECKED	APPROVED
A	NEW RELEASE	YCH 03/31/11'	~	

NOTES:

- METAL HOOD MATERIAL: Zinc alloy
- PART NUMBER CODE:  
DS1047-01 - 09 X X  
  - Packing type  
1: Mix packing  
2: Separation packing
  - Cover Material  
M: Metal(Znic alloy)
  - Positions  
09: 9pin

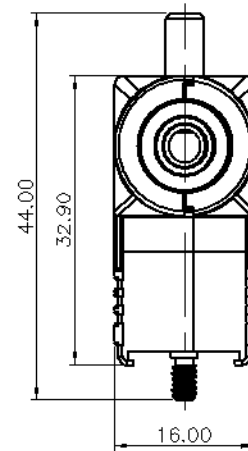
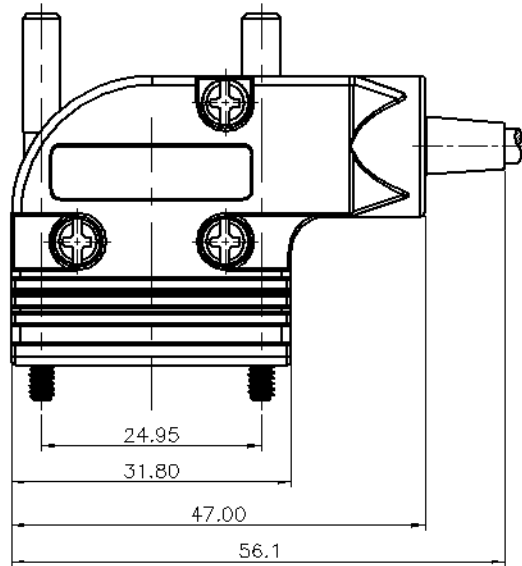

ØF	Ø
	Ø4.0
	Ø5.0
	Ø7.0
	Ø9.0

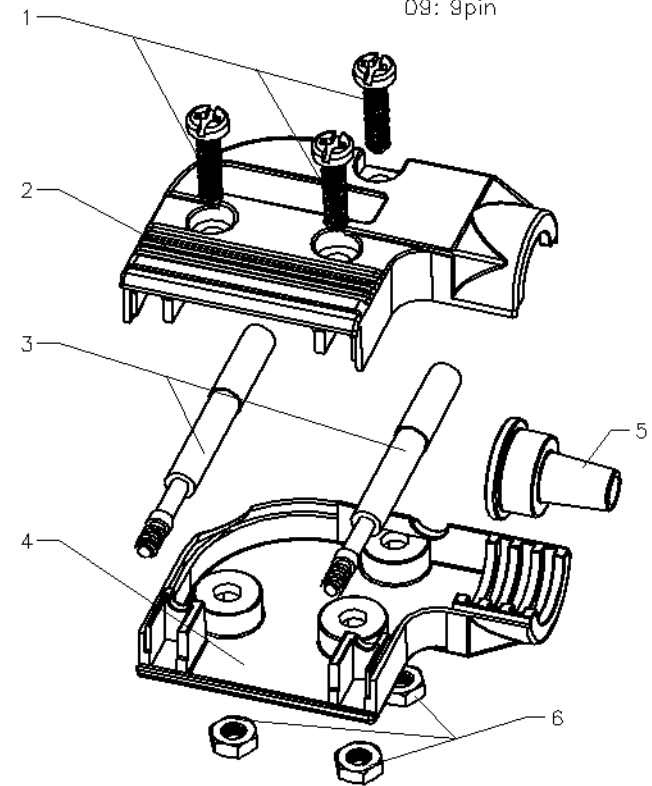
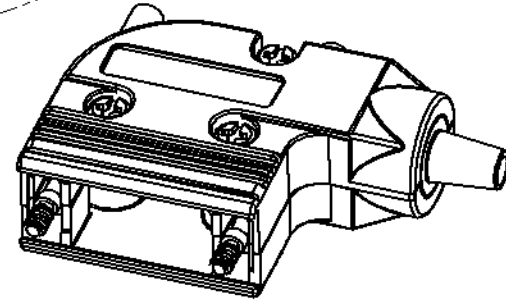
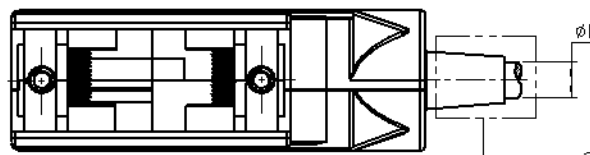
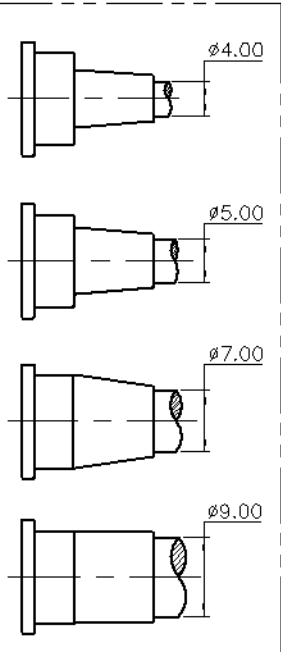

BOM LIST			
ITEM	PART NAME	Q'ty	NOTES
1	SCREW	3	M3
2	UP METAL HOOD	1	Znic alloy
3	LONG BOLT	2	UNC 4-40
4	DOWN METAL HOOD	1	Znic alloy
5	SR	4	
6	NUT	3	M3

GENERAL TOLERANCE	ANGLE TOLERANCE
X. ±0.60	X. ±5°
.X ±0.38	.X ±3°
.XX ±0.25	.XX ±2°

PROJECTION	TITLE
UNITS	D-SUB 9pin Metal Cover 90° type
SHEET SIZE	SERIES DS1047-01 SERIES

DRAWING TYPE	CUSTOMER
SCALE	1:1 SHEET 1 OF 1
DRAWING NO.	C-DS1047-01-09XX-A

**All Connectors**  
 www.allconnectors.eu | info@allconnectors.eu  
 Tel. +49 (0)711 / 358 110 20 | Fax +49 (0)711 / 358 110 25

REV.	DESCRIPTION	DRAWN	CHECKED	APPROVED
A	NEW RELEASE	YCH 03/31/11'	~	

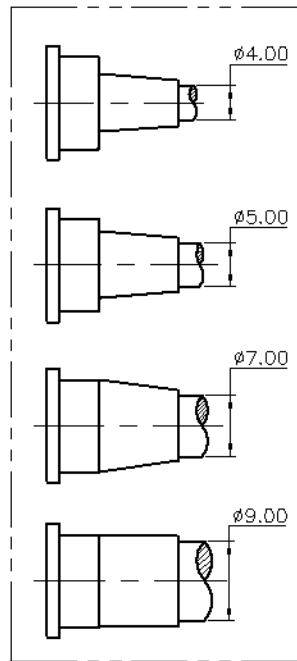
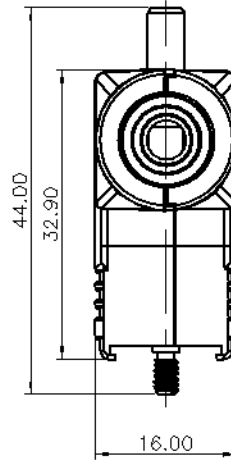
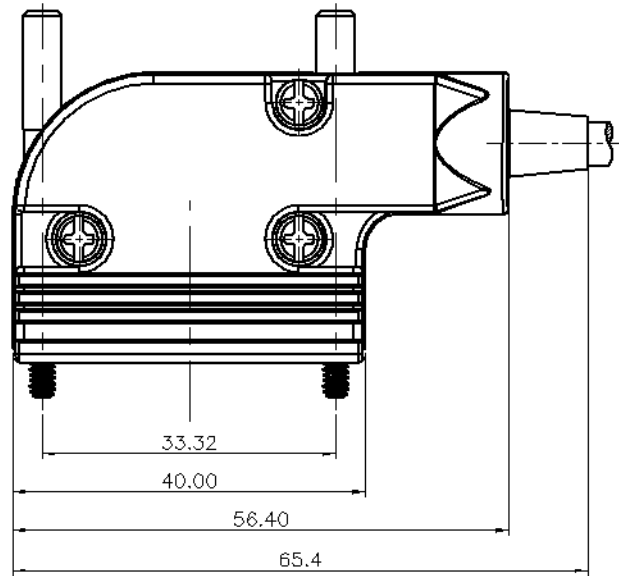

$\phi F$	
	$\phi 4.0$
	$\phi 5.0$
	$\phi 7.0$
	$\phi 9.0$

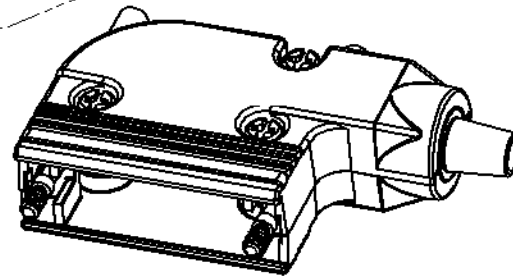
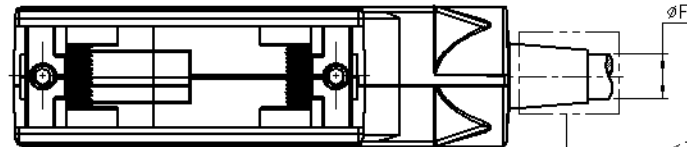

NOTES:

- METAL HOOD MATERIAL: Zinc alloy
- PART NUMBER CODE:  
DS1047-01 - 15 X X  
  - Packing type  
1: Mix packing  
2: Separation packing
  - Cover Material  
M: Metal(Znic alloy)
  - Positions  
15: 15pin

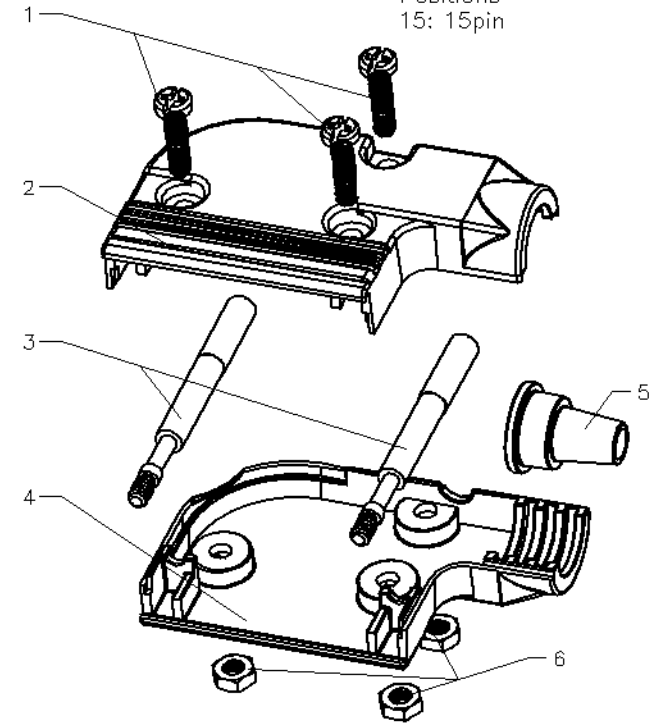

BOM LIST			
ITEM	PART NAME	Q'ty	NOTES
1	SCREW	3	M3
2	UP METAL HOOD	1	Znic alloy
3	LONG BOLT	2	UNC 4-40
4	DOWN METAL HOOD	1	Znic alloy
5	SR	4	
6	NUT	3	M3

GENERAL TOLERANCE	ANGLE TOLERANCE	PROJECTION	TITLE
X. $\pm 0.60$	X. $\pm 5^\circ$		D-SUB 15pin Metal Cover
.X $\pm 0.38$	.X $\pm 3^\circ$	mm	90° type
.XX $\pm 0.25$	.XX $\pm 2^\circ$	A4	SERIES DS1047-01 SERIES

DRAWING TYPE	CUSTOMER
SCALE	1:1 SHEET 1 OF 1
DRAWING NO.	C-DS1047-01-15XX-A

**Allconnectors**

www.allconnectors.eu | info@allconnectors.eu  
Tel. +49 (0)711 / 358 110 20 | Fax +49 (0)711 / 358 110 25

REV.	DESCRIPTION	DRAWN	CHECKED	APPROVED
A	NEW RELEASE	YCH 03/31/11'	~	

NOTES:

1. METAL HOOD MATERIAL: Zinc alloy

2. PART NUMBER CODE:

DS1047-01 - 25 X X

Packing type  
1: Mix packing  
2: Separation packing

Cover Material  
M: Metal(Zinc alloy)

Positions  
25: 25pin

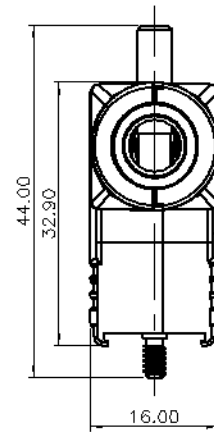
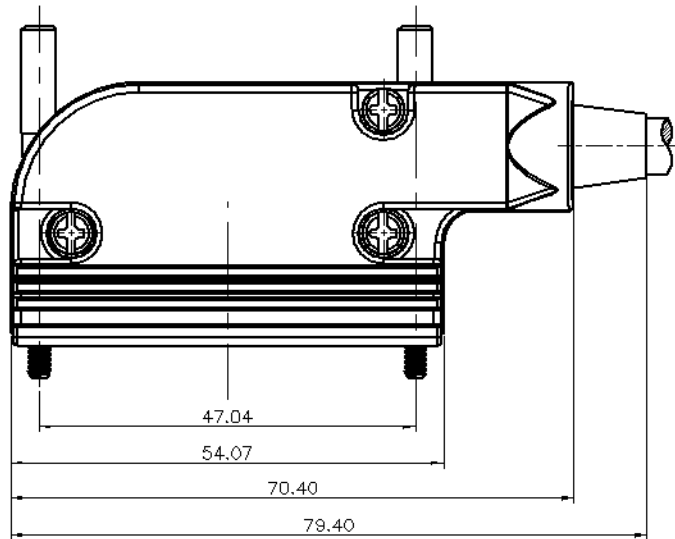

øF	ø
	ø4.0
	ø5.0
	ø7.0
	ø9.0

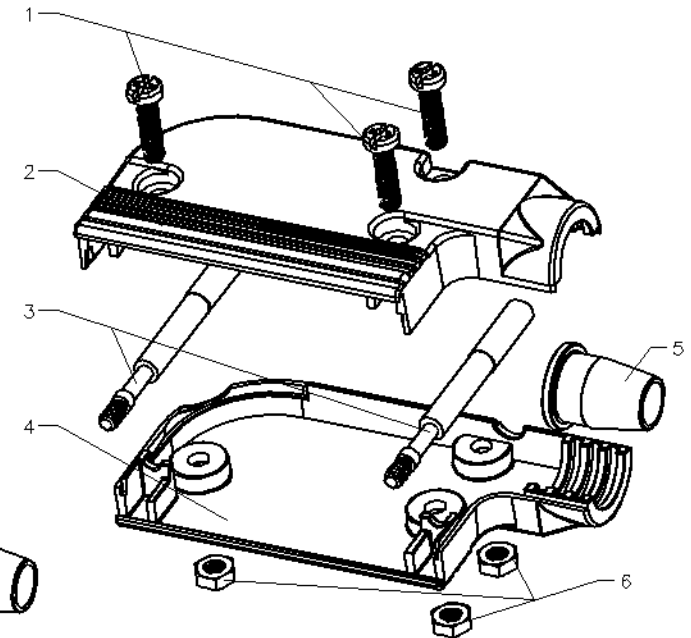
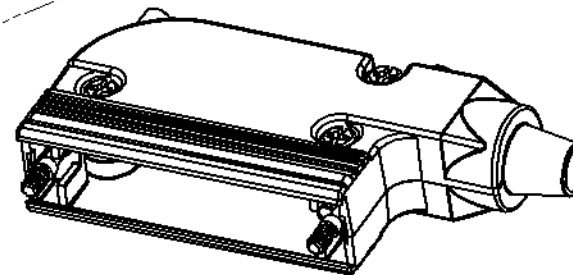
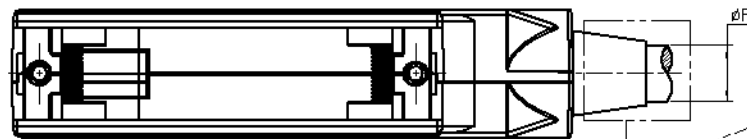
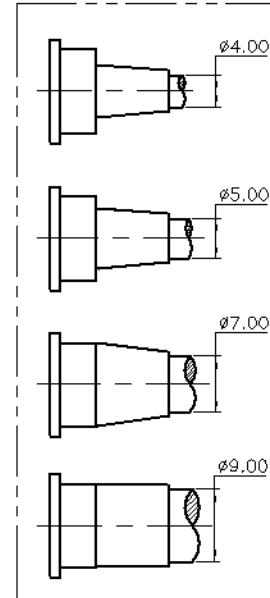

BOM LIST			
ITEM	PART NAME	Q'ty	NOTES
1	SCREW	3	M3
2	UP METAL HOOD	1	Znic alloy
3	LONG BOLT	2	UNC 4-40
4	DOWN METAL HOOD	1	Znic alloy
5	SR	4	
6	NUT	3	M3

GENERAL TOLERANCE	ANGLE TOLERANCE
X. ±0.60	X. ±5°
.X ±0.38	.X ±3°
.XX ±0.25	.XX ±2°

PROJECTION	TITLE	D-SUB 25pin Metal Cover 90° type	
UNITS	mm	SHEET SIZE	A4
SHEET SIZE	A4	SERIES	DS1047-01 SERIES

DRAWING TYPE	CUSTOMER		
SCALE	1:1	SHEET	1 OF 1
DRAWING NO.	C-DS1047-01-25XX-A		

**Allconnectors**

www.allconnectors.eu | info@allconnectors.eu

Tel. +49 (0)711 / 358 110 20 | Fax +49 (0)711 / 358 110 25

REV.	DESCRIPTION	DRAWN	CHECKED	APPROVED
A	NEW RELEASE	YCH 03/31/11'	~	

NOTES:

1. METAL HOOD MATERIAL: Zinc alloy

2. PART NUMBER CODE:

DS1047-01 - 37 X X

Packing type  
1: Mix packing  
2: Separation packing

Cover Material  
M: Metal(Zinc alloy)

Positions  
37: 37pin

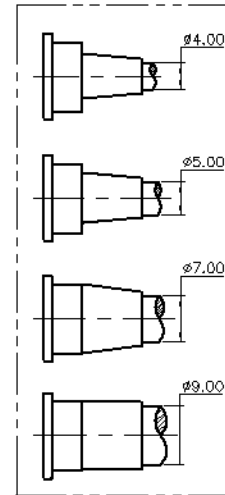
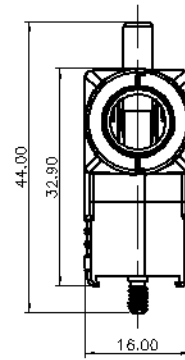
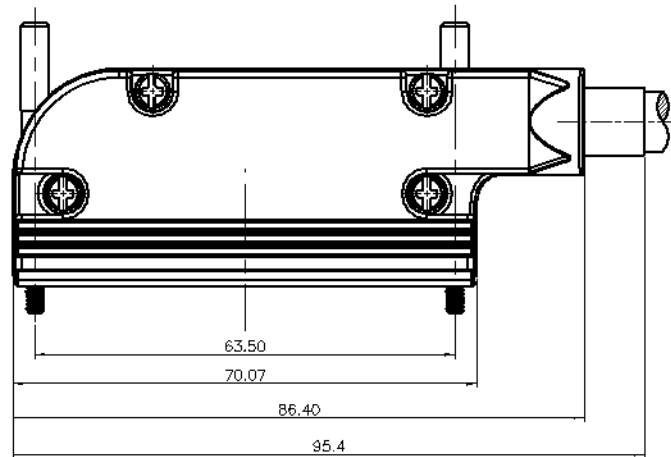

ØF	Ø
	Ø4.0
	Ø5.0
	Ø7.0
	Ø9.0

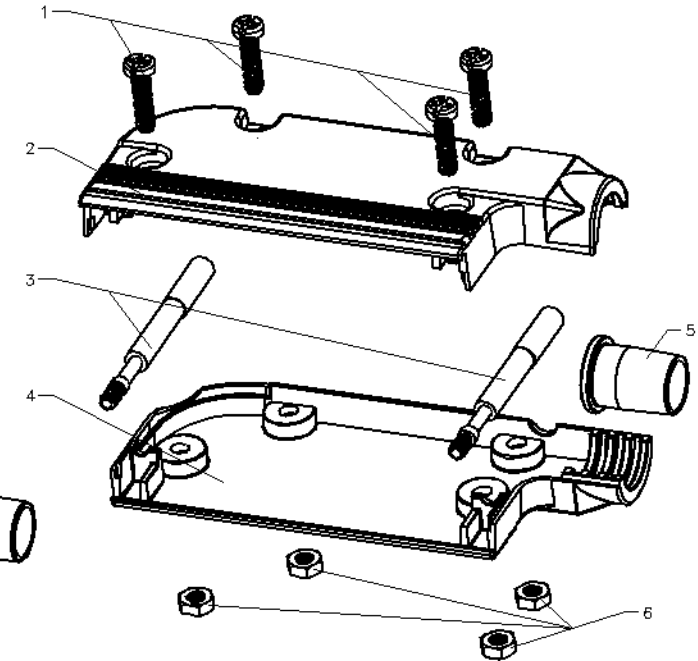
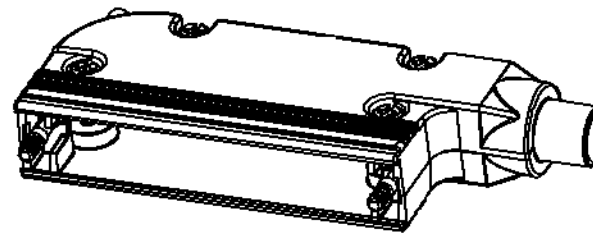
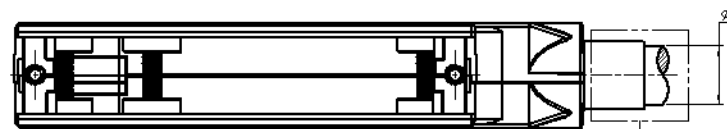

BOM LIST			
ITEM	PART NAME	Q'ty	NOTES
1	SCREW	4	M3
2	UP METAL HOOD	1	Znic alloy
3	LONG BOLT	2	UNC 4-40
4	DOWN METAL HOOD	1	Znic alloy
5	SR	4	
6	NUT	4	M3

GENERAL TOLERANCE	ANGLE TOLERANCE
X. ±0.60	X. ±5°
.X ±0.38	.X ±3°
.XX ±0.25	.XX ±2°

PROJECTION	TITLE
UNITS	D-SUB 37pin Metal Cover 90° type
SHEET SIZE	SERIES DS1047-01 SERIES

DRAWING TYPE	CUSTOMER
SCALE	1:1 SHEET 1 OF 1
DRAWING NO.	C-DS1047-01-37XX-A

**Allconnectors**

www.allconnectors.eu | info@allconnectors.eu

Tel. +49 (0)711 / 358 110 20 | Fax +49 (0)711 / 358 110 25