

REV	ECN NO.
1.1	EC2009031201

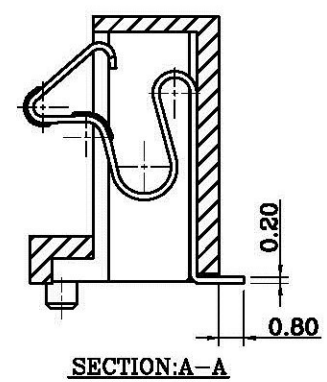
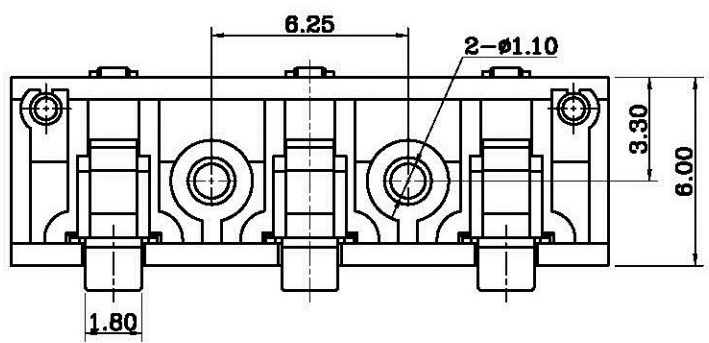
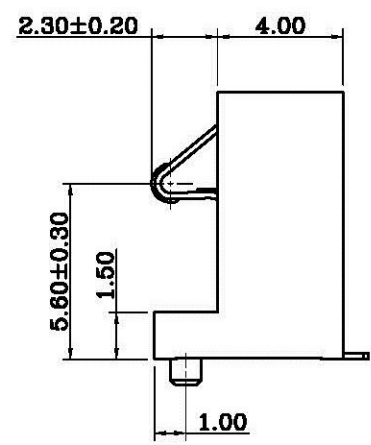
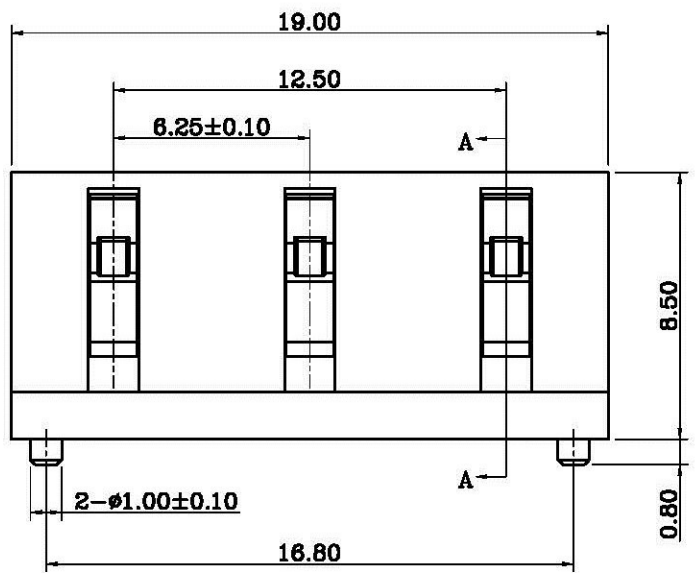

ORDERING INFORMATION

BH 117D 03 U - B X
 (1) (2) (3) (4) (5)

- SERIES NO.
117D: 3PIN BATTERY CONNECTOR
- NUMBER OF PIN
03: 3 POSITIONS
- TAIL CONSTRUCTION TYPE
U: SMD TYPE
- HOUSING COLOR CODE AND MATERIAL
B: HOUSING:BLACK COLORS MATERIAL:LCP
- CONTACT PLATING
1: GOLD FLASH OVER ALL
2: 15u" GOLD PLATING OVER ALL
3: 30u" GOLD PLATING OVER ALL

MATERIAL SPECIFICATION:

- HOUSING:LCP PLASTIC(UL94V-0) COLOR:BLACK
 - CONTACT:BERYLLIUM COPPER
- ELECTRICAL PERFORMANCE**
- RATED VOLTAGE(MAX.):100V AC/DC
 - RATED CURRENT(MAX.):1.0A AC/DC
 - DIELECTRIC STRENGTH:500V AC FOR 1 MINUTE BETWEEN ADJACENT TERMINAL, NO BREAKDOWN
 - INSULATION RESISTANCE:1000 MEGOHMS MIN. 500V DC FOR 1 MINUTE BETWEEN ADJACENT TERMINAL
 - CONTACT RESISTANCE:50 MILLIOHM MAX.
 - OPERATING TEMPERATURE:-25° to +85°

G	5				DRAWING:	GENERAL TOLERANCE			
	4				<i>Match</i>	X:±0.30	X':±2°		
	3				CHECKED:	XX:±0.15	XX':±1°		
	2				<i>Fahr</i>	XXX:±0.10	XXX':±0.5°		
	1	20090312	修改尺寸	<i>Match</i>	APPROVAL:	UNIT: MM	PROJECTION:	DESCRIPTION:	
H	NO.	DATE	DESCRIPTION	APPROVAL	<i>Felix</i>	SCALE: 1/1		3Pin BATTERY CONNECTOR	
						SHEET: 1/1		PART NO: BH117D03U-B1	REV: 1.1
							DRAWING NO: P1BH117D03U-B1-01	SIZE: A4	