

REV.	DESCRIPTION	ECN NO.	DATE	DRAWER
A	New Release		03/02/2006	Tom
B	Add Part No. $\triangle_B$ x 1	EC0903005	03/03/2009	Tom

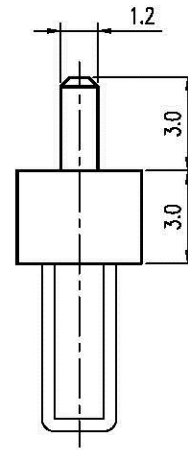

- $\triangle_B$  Notes:
- Material :  
Housing : Thermoplastic, UL 94V-0  
Terminal : Copper Alloy
  - Finish :  
Terminal : Selected Gold on Contact Area, 1u" Min. Gold on Solder Tails, Both over 50u" Min. Ni Under-plated Overall
  - Order Information :  
TSB1-051 X 2-22T X
- Amount of Pins
- 3 : 3 Pins
  - 2 : 2
  - 9 : 9 Pins
  - A : 10 Pins
  - 2 : 2
  - B : 11 Pins
- Plating
- 2 : 2u" Min. Gold on Contact Area
  - 3 : 5u" Min. Gold on Contact Area
  - 8 : 30u" Min. Gold on Contact Area

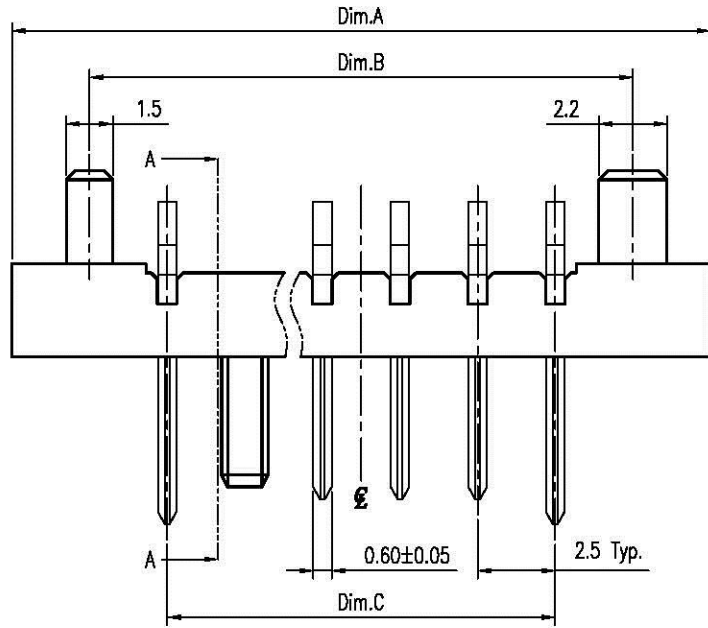
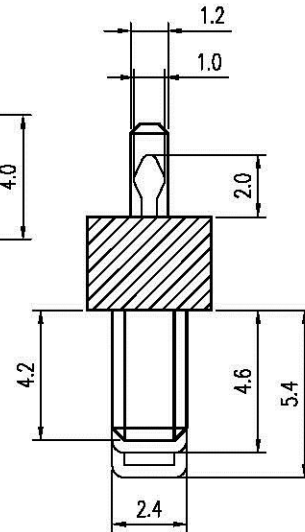
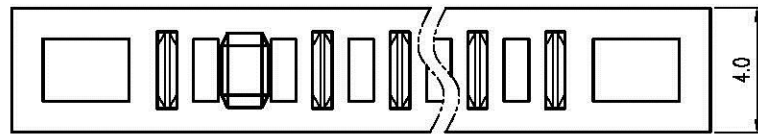

Section A-A

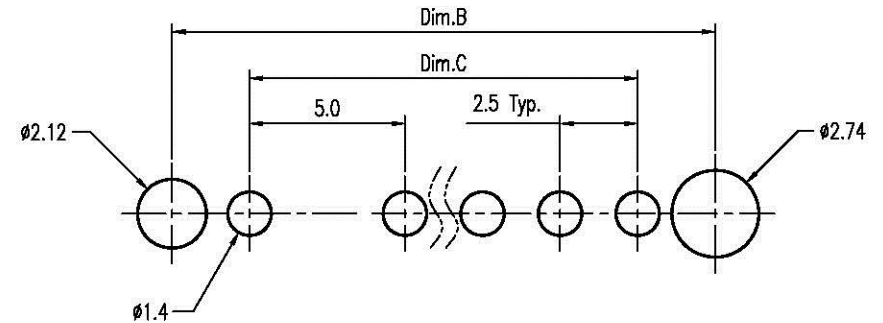

Recommended P.C.B. Layout  
Layout Tolerance =  $\pm 0.05$  mm

Dimension Information:

Part No.	Dim.	Amount of Pins	Dim.A	Dim.B	Dim.C
TSB1-05132-22TX	3		17.5	12.5	7.5
TSB1-05142-22TX	4		20.0	15.0	10.0
TSB1-05152-22TX	5		22.5	17.5	12.5
TSB1-05162-22TX	6		25.0	20.0	15.0
TSB1-05172-22TX	7		27.5	22.5	17.5
TSB1-05182-22TX	8		30.0	25.0	20.0
TSB1-05192-22TX	9		32.5	27.5	22.5
TSB1-051A2-22TX	10		35.0	30.0	25.0
TSB1-051B2-22TX	11		37.5	32.5	27.5

DIMENSION IN mm [inch]	
Tolerance unless otherwise specified	
X. $\pm 0.38$	X.' $\pm 10'$
X.X $\pm 0.25$	X.X' $\pm 5'$
X.XX $\pm 0.20$	X.XX' $\pm 2'$
X.XXX $\pm$	X.XXX' $\pm$

**All Connectors**

www.allconnectors.com  
Tel: 0049 711 7009228  
All-Right Holder GmbH - Germany

info@allconnectors.com  
Fax: 0049 711 7009204  
Kollmannstr. 29

**CUSTOMER DRAWING**

Approver:

Checker:

Drawer: **Tom**

03/03/2009

Title **2.5mm Pitch Battery Conn. Male Type**

Dwg No. **TSB1-051X2-22TX**

File No. **PO3015**

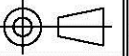

Scale: **4 : 1**

Size: **A 4**

Rev : **B**

Sheet: **1 / 1**