

REV.	DESCRIPTION	ECN NO.	DATE	DRAWER
A	New Release		02/26/2007	Alan

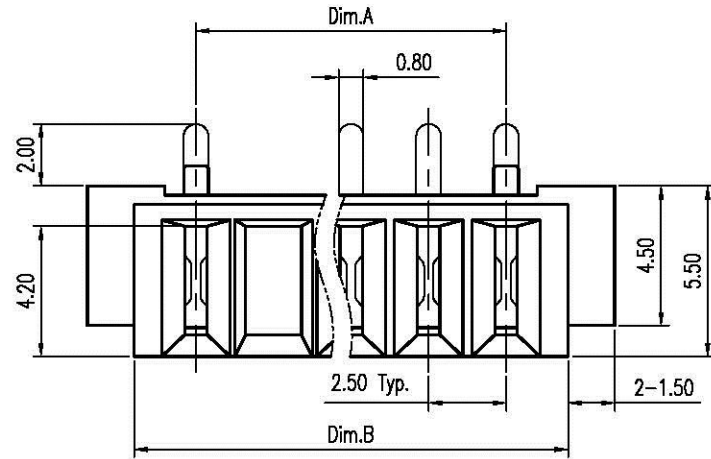

Notes:

- Material :
Housing : Thermoplastic UL 94V-0, Black
Terminal : Copper Alloy
- Finish :
Terminal : Selected Gold on Contact Area, Gold Flash on Solder Tails, Both over 50u" Min. Ni Under-plated Overall
- Order Information :
TSB0-022 X 2-10T X

Amount of Pins	Plating
3 : 3 Pins	2 : 2u" Min. Gold on Contact Area
5 : 5	3 : 5u" Min. Gold on Contact Area
A : 10 Pins	5 : 15u" Min. Gold on Contact Area
	8 : 30u" Min. Gold on Contact Area

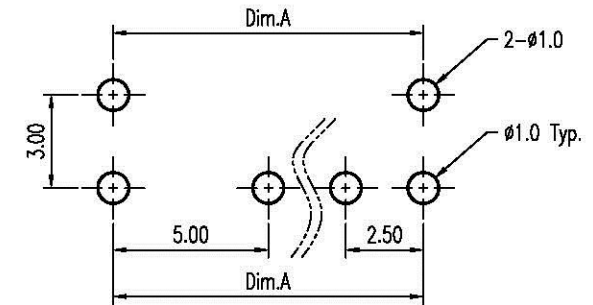
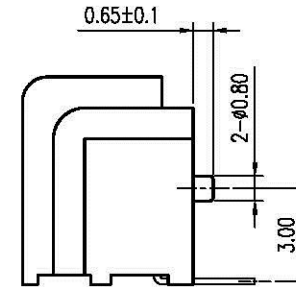
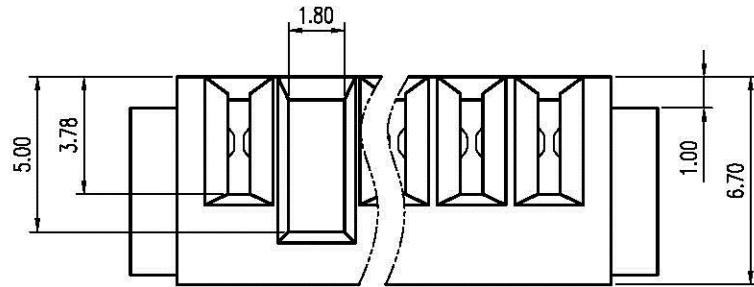

Recommended P.C.B. Layout
Layout Tolerance = ± 0.05 mm

Part No.	Dim.	Dim.A	Dim.B
TSB0-02232-10TX		7.50	11.50
TSB0-02242-10TX		10.00	14.00
TSB0-02252-10TX		12.50	16.50
TSB0-02262-10TX		15.00	19.00
TSB0-02272-10TX		17.50	21.50
TSB0-02282-10TX		20.00	24.00
TSB0-02292-10TX		22.50	26.50
TSB0-022A2-10TX		25.00	29.00

DIMENSION IN mm [inch]	
Tolerance unless otherwise specified	
X. ±	X.' ± 10'
X.X ± 0.38	X.X' ± 5'
X.XX ± 0.25	X.XX' ± 2'
X.XXX ± 0.13	X.XXX' ±

All Connectors

www.allconnectors.com
Tel: 0049 711 7095933
79794 Filtenstadt, Germany
info@allconnectors.com
Fax: 0049 711 7095924
Koblenzstr. 23

CUSTOMER DRAWING

Approver:

Checker:

Drawer: Alan

02/26/2007

Title 2.5mm Pitch Battery Conn.
Female Type

Dwg No. TSB0-022X2-10TX

File No. P01009

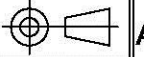

Scale: 1 : 1

Size: A 4

Rev : A

Sheet: 1 / 1