

REV.	DESCRIPTION	ECN NO.	DATE	DRAWER
A	New Released		05/27/2010	Hyde

**Notes:**

- Material :**  
Housing : Thermoplastic UL 94V-0 , Black  
Terminal : Copper Alloy
- Finish :**  
Terminal : Selected Gold on Contact Area, Gold Flash on Solder Tails, Both over 40u" Min. Ni Under-plated Overall  
Forklock : 80u" Tin. over 40u" Min. Ni Under-plated Overall.
- Order Information :**  
T SA1-224 07 -00 X X A  
T : RoHS(for High Temperature)  
**Amount of Pins:**  
07: 7Pins  
**Packing Option:**  
T : Tube  
1 : Tube+Cap  
2 : Reel+Cap  
**Plating :**  
2 : 2u" Min. Gold on Contact Area  
3 : 5u" Min. Gold on Contact Area

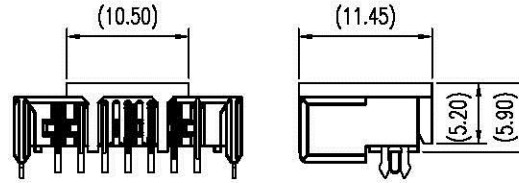
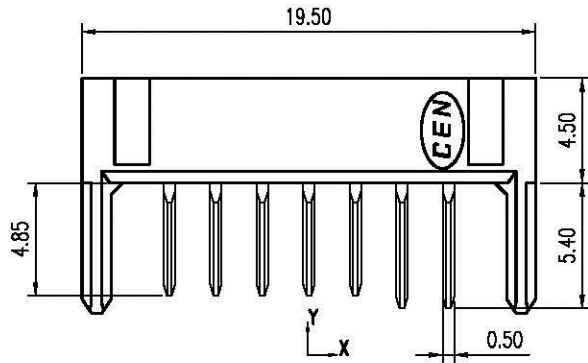

With CAP  
Scale 6:1

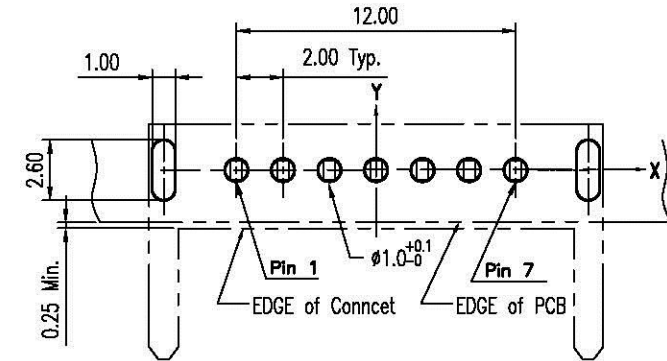
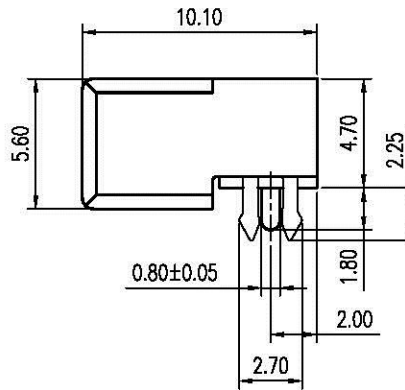
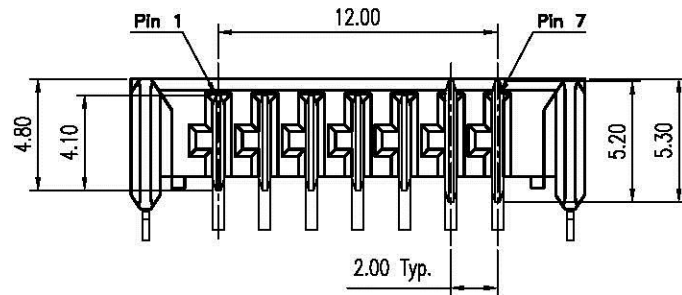

**Recommended P.C.B. Layout**  
Layout Tolerance =  $\pm 0.05$  mm

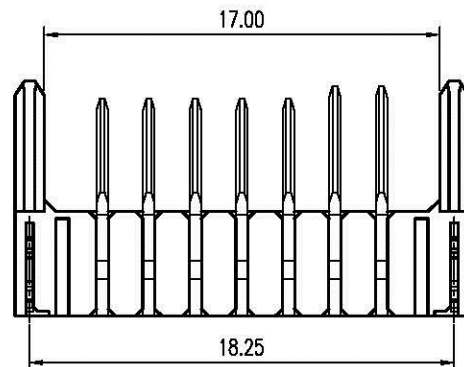

DIMENSION IN mm [inch]		Allconnectors	Title		Scale: 3 : 1
Tolerance unless otherwise specified			2.0mm Pitch Battery Conn. Male Type		
X.	X.' $\pm 10'$	<small>www.allconnectors.com Tel.: 0049 711 7094619 70524 Hiltlstraße - Germany</small> <small>Info: @allconnectors.com Fax: 0049 711 7094624 Kettnerstr. 25</small>	Dwg No.	SA1-22407-00XXA	Size: A 4
X.X $\pm 0.38$	X.X' $\pm 5'$		CUSTOMER DRAWING		Rev: A
X.XX $\pm 0.25$	X.XX' $\pm 2'$		File No.	PO9017	Sheet: 1 / 1
X.XXX $\pm 0.13$	X.XXX' $\pm$		Approver:	Checker:	Drawer: Hyde 05/27/2010