

REV.	DESCRIPTION	ECN NO.	DATE	DRAWER
A	New Release		11/26/2009	Jeff
B	Added Type \triangle_B x4	EC0912021	12/11/2009	Jeff

Notes:

- Material :
 Housing : Thermoplastic UL 94V-0, Black
 Forklock : Copper Alloy
 Terminal : Copper Alloy
 Cap : Thermoplastic UL 94V-0, Black
- Finish :
 Terminal : Selected Gold on Contact Area, Gold Flash on Solder Tails, Both over 50u" Min. Ni Under-plated Overall
 Forklock : 80u" Min Tin over 50u" Min. Ni Under-plated Overall.

3. Order Information :

TSA1-2150 9- 00 X X A

Amount of Pins
9 : 9 Pins

Plating

2 : 2u" Min. Gold on Contact Area \triangle_B
 3 : 5u" Min. Gold on Contact Area \triangle_B
 8 : 30u" Min. Gold on Contact Area

Packing

\triangle_B 1 : Cap + Tube
 2 : Cap + Reel

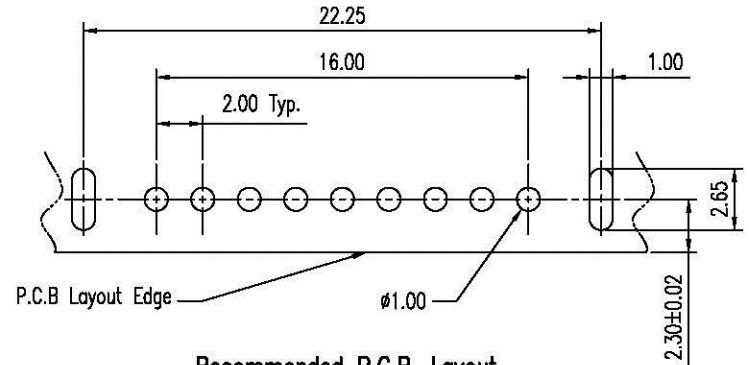
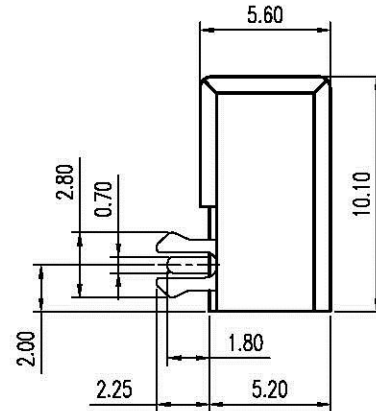
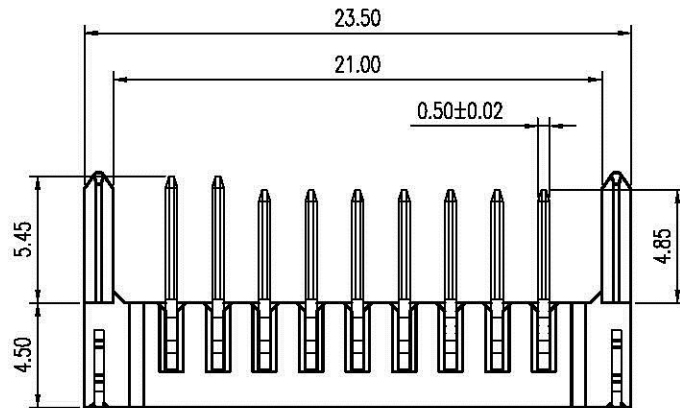
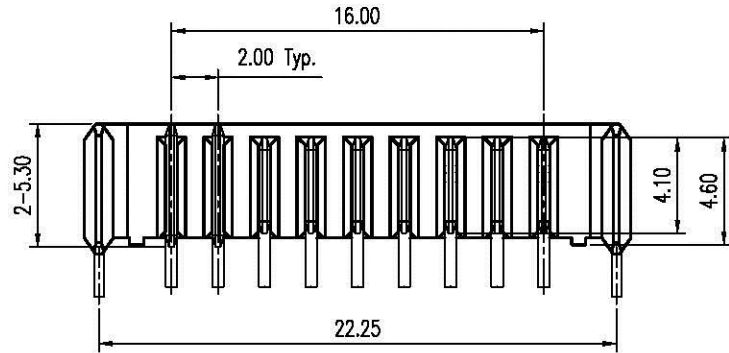

Recommended P.C.B. Layout
 Layout Tolerance = ± 0.05 mm
 P.C.B Thickness = 1.20mm

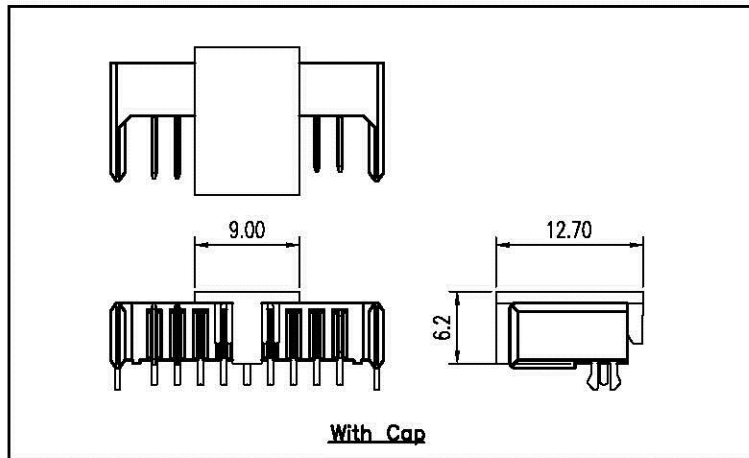

DIMENSION IN mm [inch]	
Tolerance unless otherwise specified	
X. ±	X.' ± 10'
X.X ± 0.38	X.X' ± 5'
X.XX ± 0.25	X.XX' ± 2'
X.XXX ± 0.13	X.XXX' ±

Allconnectors

www.allconnectors.de
 info@allconnectors.de
 info@allconnectors.com
 info@allconnectors.com

CUSTOMER DRAWING

Approver:

Checker:

Drawer: Jeff

12/11/2009

