

REV.	DESCRIPTION	ECN NO.	DATE	DRAWER
A	New Released		03/02/2010	LeoLiou

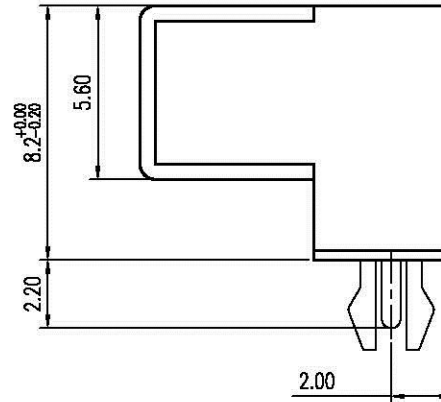
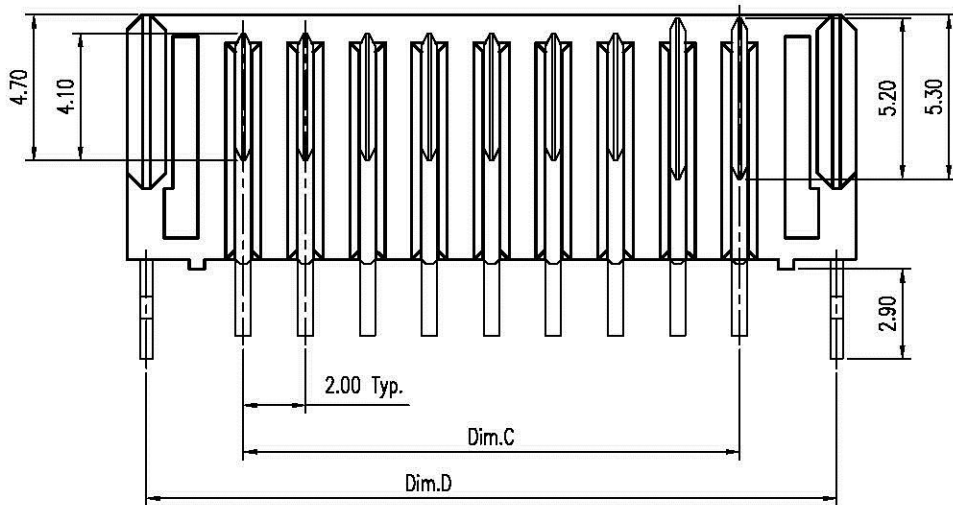
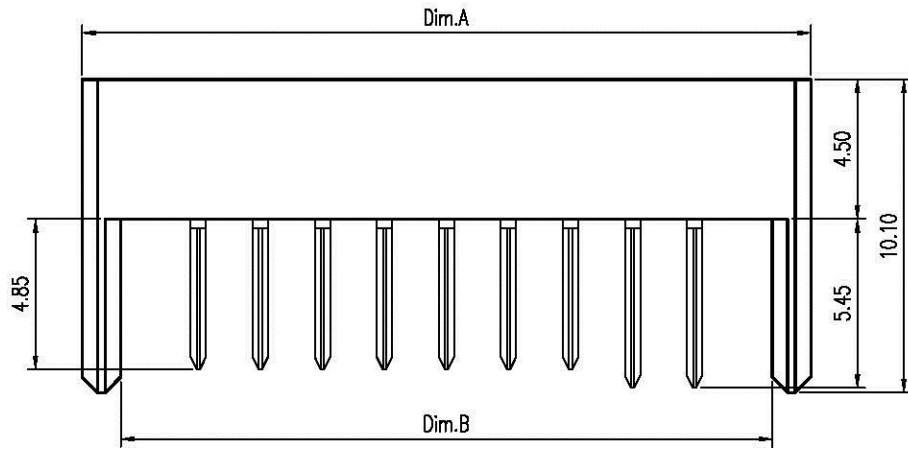

Notes:

- Material :
Housing : Thermoplastic, UL 94V-0, Black
Terminal : Copper Alloy
Forklock : Copper Alloy
- Finish :
Terminal : Selected Gold on Contact Area,
Gold Flash on Solder Tails,
Both over 50u" Min. Ni Under-plated Overall
Forklock : Gold Flash Over 50u" Min. Ni Under-plated Overall.
- Recommended P.C.B. Thickness : 1.5 mm
- Order Information :

TSA1-104 09 -02T X A
 T: RoHS (for High Temperature)
 Amount of Pins
 09 : 9 Pins
 Plating
 2 : 2u" Min. Gold on Contact Area
 3 : 5u" Min. Gold on Contact Area

Dimension Information:

Part No.	Dim.	Amount of Pins	Dim.A	Dim.B	Dim.C	Dim.D
TSA1-10409-02TXA		9	23.5	21.00	16.00	22.25

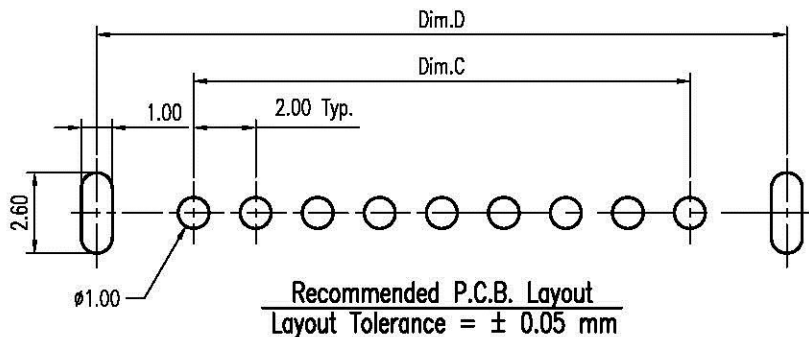

DIMENSION IN mm [inch]	
Tolerance unless otherwise specified	
X.	X.' ± 10'
X.X ± 0.38	X.X' ± 5'
X.XX ± 0.25	X.XX' ± 2'
X.XXX ± 0.13	X.XXX' ±

All Connectors

www.allconnectors.de
 Tel.: 0648 711 7068903
 70794 Filcrstadt Germany
 Info@allconnectors.de
 Fax: 0648 711 7069004
 Kette 14/09 22

CUSTOMER DRAWING

Approver:

Checker:

Drawer: **LeoLiou**

03/02/2010

