

REV.	DESCRIPTION	ECN NO.	DATE	DRAWER
A	New Release		12/30/2008	Steven
B	Modified Plating \triangle x1	EC0911049	11/13/2009	Hyde

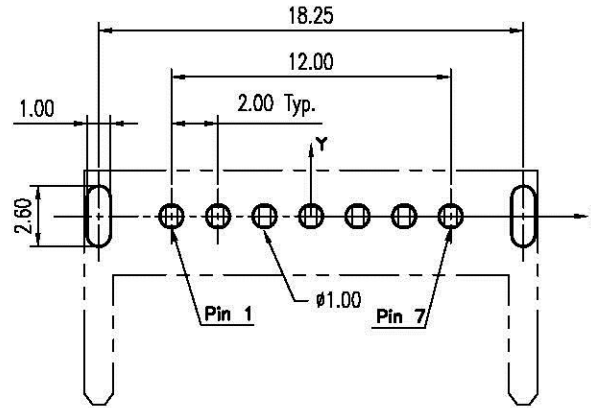

Recommended P.C.B. Layout-1
Layout Tolerance = ± 0.05 mm

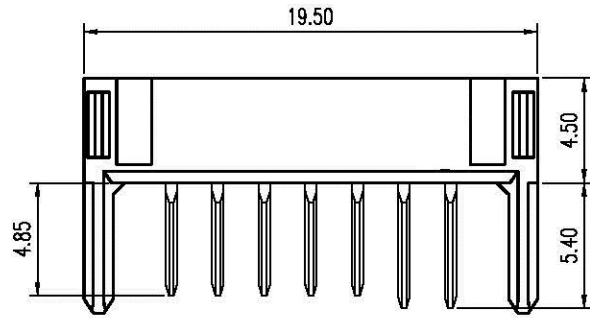
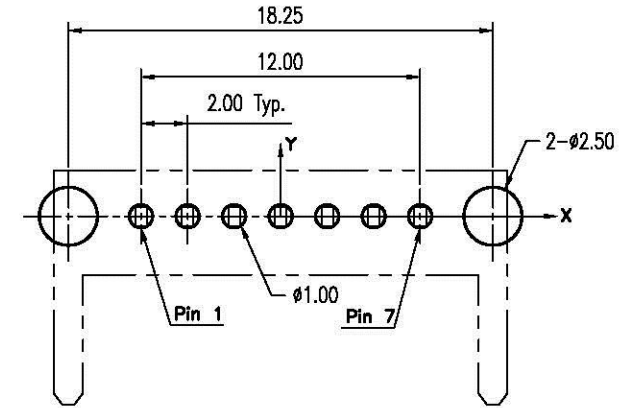

Recommended P.C.B. Layout-2
Layout Tolerance = ± 0.05 mm

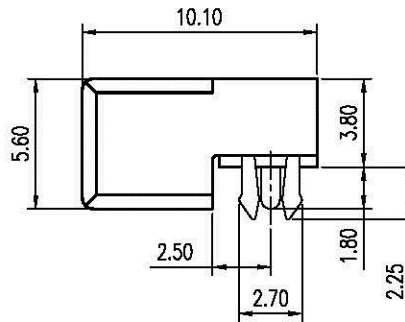
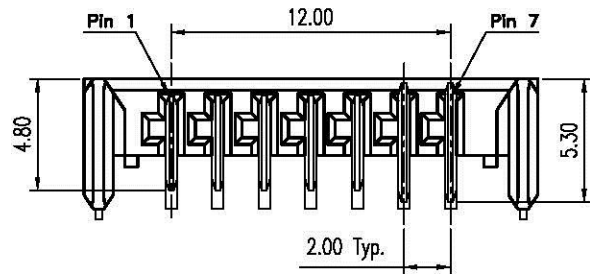

Notes:

- Material :
Housing : Thermoplastic UL 94V-0 , Black
Terminal : Copper Alloy
- Finish :
Terminal : Selected Gold on Contact Area, Gold Flash on Solder Tails, Both over 40u" Min. Ni Under-plated Overall
- Forklock : 80u" Tin. over 40u" Min. Ni Under-plated Overall.

3. Order Information :

T SA1-03A07-04T XA

T : RoHS(for High Temperature)

Plating :

- 2 : 2u" Min. Gold on Contact Area
- 3 : 5u" Min. Gold on Contact Area

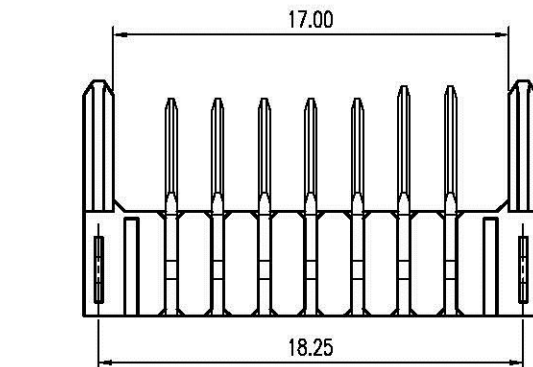

DIMENSION IN mm [inch]	
Tolerance unless otherwise specified	
X.	X.' $\pm 10'$
X.X ± 0.38	X.X' $\pm 5'$
X.XX ± 0.25	X.XX' $\pm 2'$
X.XXX ± 0.13	X.XXX' \pm

Allconnectors

www.allconnectors.de
Tel.: 0246 711 7993523
info@allconnectors.de
Fax: 0246 711 2066924
allconnectors.de

CUSTOMER DRAWING

Approver:

Checker:

Drawer: **Hyde**

11/13/2009

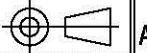

Scale: 3 : 1

Size: A 4

Rev : B

Sheet: 1 / 1