

REV.	DESCRIPTION	ECN NO.	DATE	DRAWER
A	New Release		02/19/2009	Alan

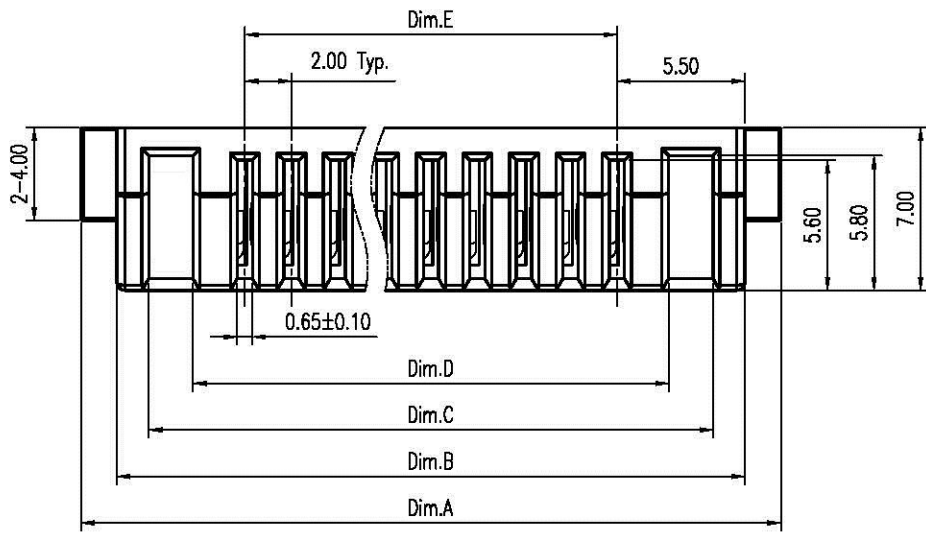

Notes:

1. Material :
Housing : Thermoplastic UL 94V-0, Black
Terminal : Copper Alloy
2. Finish :
Terminal : Selected Gold on Contact Area, Gold Flash on Solder Tails, Both over 50u" Min. Ni Under-plated Overall
3. Order Information :

TSA0-120 X 0-00T X

Amount of Pins	Plating	
8 : 8 Pins	2 : 2u"	Min. Gold on Contact Area
9 : 9 Pins	3 : 5u"	Min. Gold on Contact Area

Part No.	Dim.	Dim.A	Dim.B	Dim.C	Dim.D	Dim.E	Dim.F
TSA0-12080-00TX	28.10	25.00	22.25	18.45	14.00	19.00	
TSA0-12090-00TX	30.10	27.00	24.25	20.45	16.00	21.00	

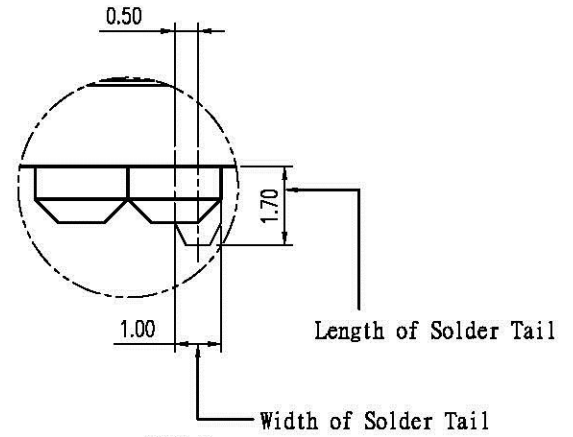
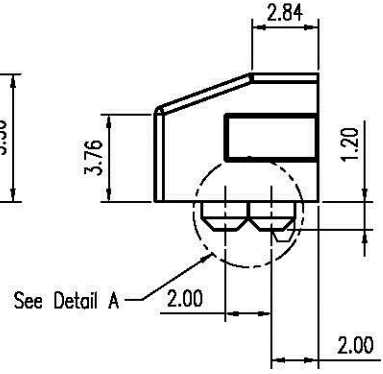
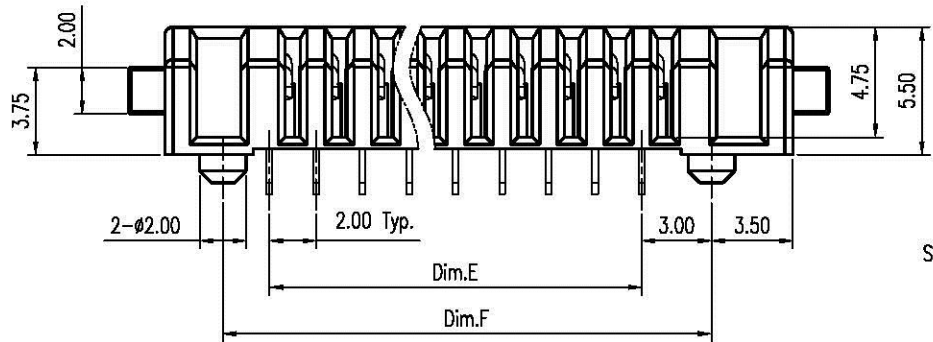

Detail A
Scale 6 : 1

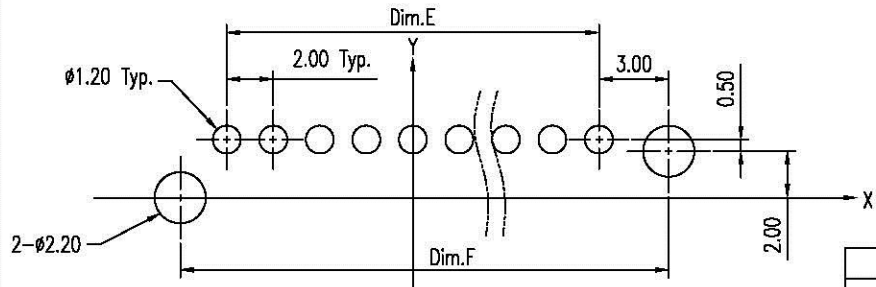

Recommended P.C.B. Layout
Layout Tolerance = ± 0.05 mm

DIMENSION IN mm [inch]		Tolerance unless otherwise specified	
X.	±	X.'	± 10'
X.X	± 0.38	X.X'	± 5'
X.XX	± 0.25	X.XX'	± 2'
X.XXX	± 0.13	X.XXX'	±

All Connectors
www.allconnectors.de
Tel: 0345 711 7005/503
70724 Filzschütz - Germany

Info@allconnectors.de
Fax: 0345 711 7005/504
Kettnerstr. 25

CUSTOMER DRAWING

Approver: _____
Checker: _____

Title	2.0mm Pitch Battery Conn. Female Type
Dwg No.	TSA0-120X0-00TX
File No.	PO8034
Drawer:	Alan
Date:	02/19/2009

Scale:	3 : 1
Size:	A 4
Rev :	A
Sheet:	1 / 1