

This document is the property of Nan-Yeong Corporation and is delivered on the express condition that it is not to be disclosed, reproduced or used, in whole or in part, for manufacture or sale by anyone other than Nan-Yeong Corporation without its prior consent, and that no right is granted to disclose or to use any information in this document.

CUSTOMER DRAWING

REV.	DESCRIPTION	APPROVED BY	DATE	ECN NO.
A	RELEASE	Fido Veng	13/02/09*	
B	Change DIM & Material.	Fido Veng	08/14/06*	
C	Change DIM & Material.	Fido Veng	09/06/06*	

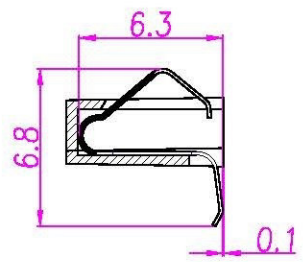
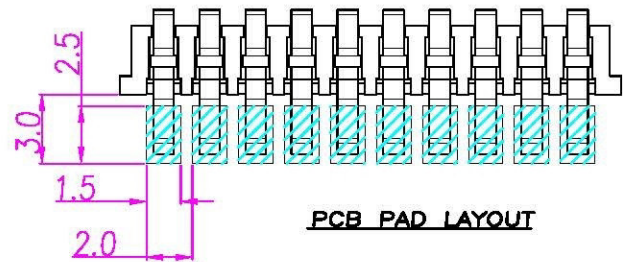
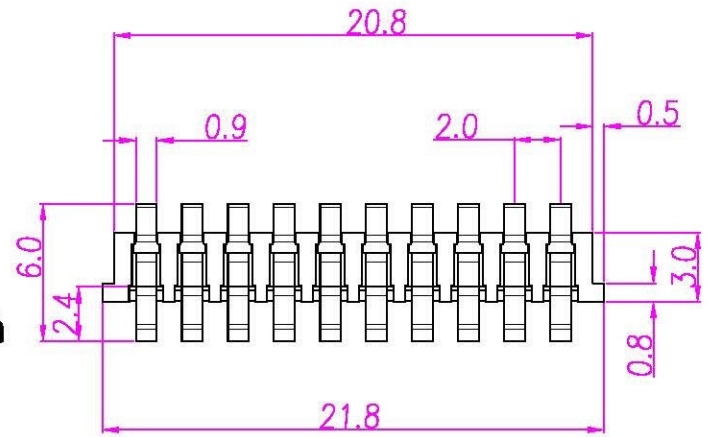
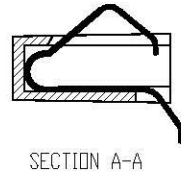
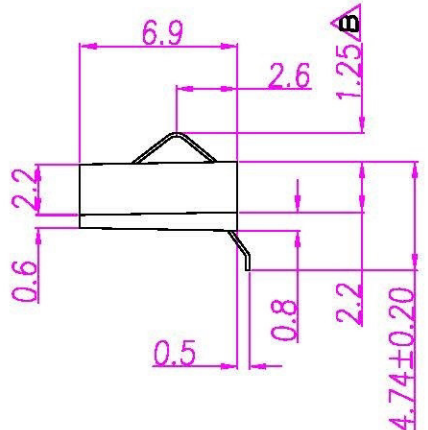
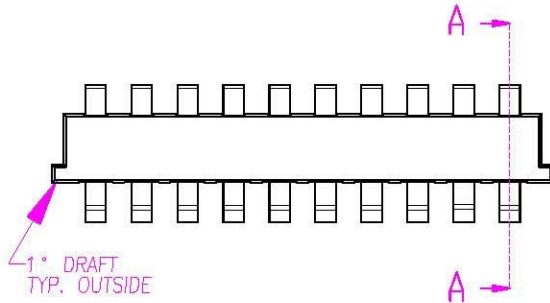
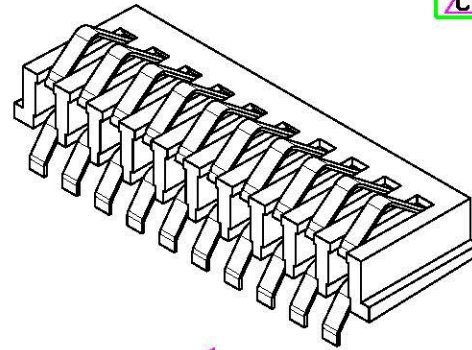
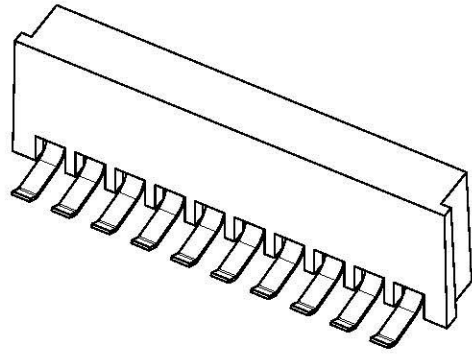

- NOTES:
1. DIMENSIONS: mm.
 2. MATERIAL:
HOUSING: PBT (BLACK) **C**
CONTACTS: 0.15 +0.07/-0.02 BERYLLIUM COPPER WITH MINIMUM HARDNESS OF 280 DPH (VICKERS) @ 500 GRAM LOAD.
 3. PLATING: .0005 MIN GOLD ON MATING AREAS, .0025 MIN NICKEL UNDER PLATED ON ENTIRE CONTACT.
 4. REMOVE FLASH AND SHARP EDGES.
 5. NORMAL FORCE AT WORKING POSITION: 80g MIN.
 6. PACKAGING: TRAY OR TUBE.
 7. UNDIMENSIONED GEOMETRY IS CONTROLLED BY SOLID MODEL FILE 330-00486-00.SLDPRT, SURFACE PROFILE TO WITHIN 0.25.
 8. THIS PART SHALL NOT CONTAIN HAZARDOUS SUBSTANCES EXCEEDING LEVELS DEFINED BY EU DIRECTIVE 2002/95/EC (RoHS).

DRAWN	Yeh Chou	APP'D	Fido Veng	UNIT	mm	TOLERANCE				TITLE	電線座 10PIN			
CHK'D	Emily Suen			SCALE	1:1	.x ±0.10 .xx ±0.05 .xxx ±0.03 .xxxx ±0.01 ANGULA ±1°				www.allconnectors.com TEL: 0049 711 408568 40734 Filderstadt - Germany	info@allconnectors.com FAX: 0049 711 408569 Kettelerstr. 29	PART NO.	HD-10F2-01	