

REV.	DESCRIPTION	ECN NO.	DATE	DRAWER
A	New Release		09/11/2009	Jeff
B	Added Plating $\triangle_B \times 3$	EC0910077	10/30/2009	Jeff
C	Added Amount $\triangle_C \times 2$	EC1205045	06/01/2012	Wang

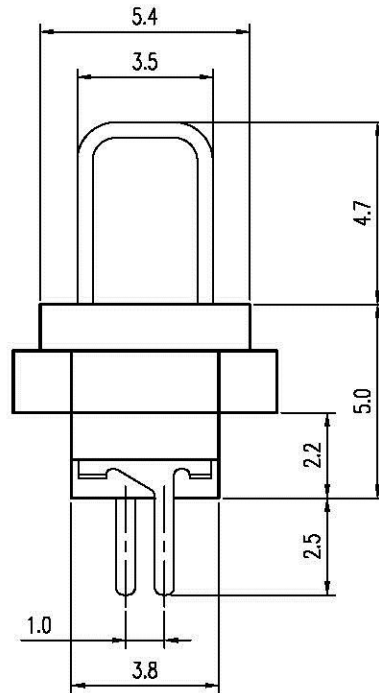

Notes:

- Material:  
Housing: Thermoplastic UL 94V-0, Black  
Terminal: Copper Alloy
- Finish:  
 $\triangle_B$  Terminal: Selected Gold on Contact Area, 70u" Min. Tin or Gold Flash on Solder Tails, Both over 50u" Min. Ni Under-plated Overall
- Order Information:

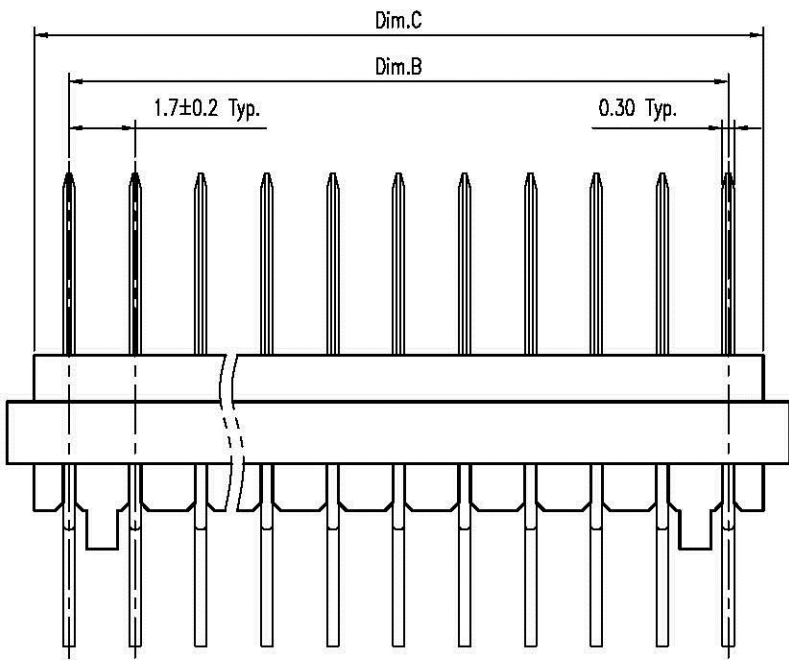
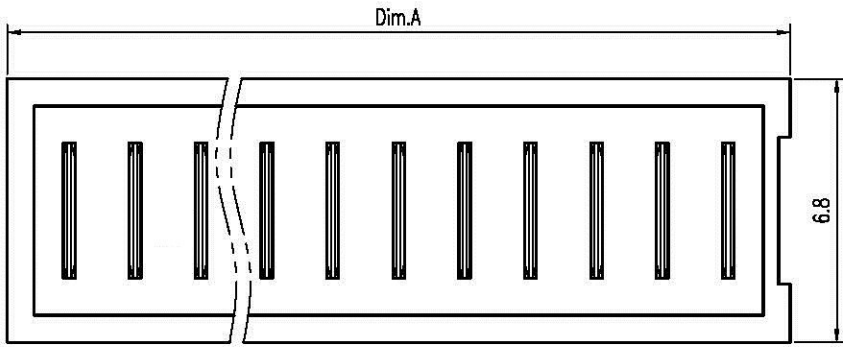
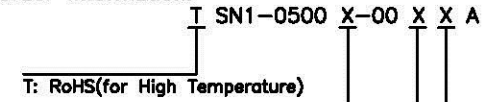

- $\triangle_C$  Amount of Pins :
- 5: 5 Pins
  - 8: 8 Pins
  - B: 11 Pins
- Packing  
T: Tube

- Plating
- $\triangle_B$ : 2u" Min. Gold on Contact Area, 70u" Min. Tin on Solder Tails.
  - $\triangle_B$ : 5u" Min. Gold on Contact Area, 70u" Min. Tin on Solder Tails.
  - 2: 2u" Min. Gold on Contact Area, Gold Flash on Solder Tails.
  - 3: 5u" Min. Gold on Contact Area, Gold Flash on Solder Tails.

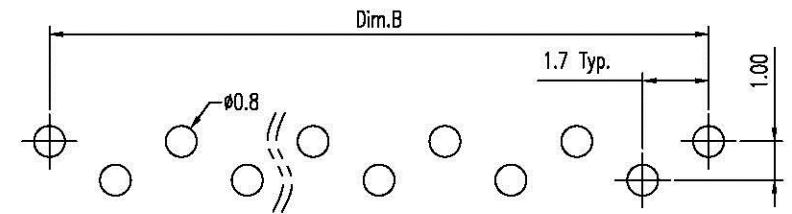

Recommended P.C.B. Layout  
Layout Tolerance =  $\pm 0.05$  mm

Dimension Information:

Part No.	Dim.	Dim.A	Dim.B	Dim.C
$\triangle_C$ TSN1-05005-00XXA		10.0	6.8	8.6
TSN1-05008-00XXA		15.1	11.9	13.7
TSN1-0500B-00XXA		20.2	17.0	18.8

DIMENSION IN mm [inch]			
Tolerance unless otherwise specified			
X.	$\pm 0.38$	X.'	$\pm 10'$
X.X	$\pm 0.25$	X.X'	$\pm 5'$
X.XX	$\pm 0.15$	X.XX'	$\pm 2'$
X.XXX	$\pm$	X.XXX'	$\pm$

Allconnectors

www.allconnectors.de  
Tel: 0346 711 709540  
Fax: 0346 711 709594  
Kettenerstr. 27

Title 1.7mm Pitch Battery Conn.  
Male Type

Dwg No. TSN1-0500X-00XXA

File No. P12018

Approver:

Checker:

Drawer: Wang

06/01/2012

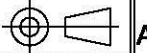

Scale: 5 : 1

Size: A 4

Rev : C

Sheet: 1 / 1